

Olof Petersson
Monika Djerf-Pierre
Sören Holmberg
Jesper Strömbäck
Lennart Weibull

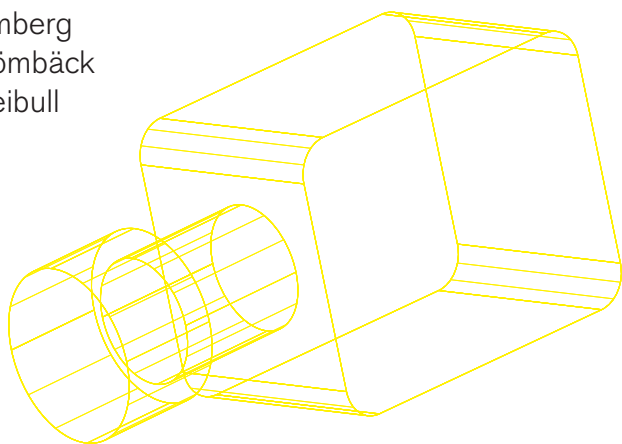

Report from the Democratic
Audit of Sweden 2006
Media and Elections in Sweden



SNSFÖRLAG

Report from the Democratic Audit of Sweden 2006

Olof Petersson
Monika Djerf-Pierre
Sören Holmberg
Jesper Strömbäck
Lennart Weibull

SNS MEDIEFORUM

Report from the Democratic
Audit of Sweden 2006
**Media and Elections
in Sweden**

Translated by Charly Hultén

SNS FÖRLAG

SNS Förlag
Box 5629
1 14 86 Stockholm
Tel. + 46 8 507 025 00
Fax +46 8 507 025 25
E-mail: info@sns.se
www.sns.se

SNS – Centre for Business and Policy Studies

SNS is an independent network of leading decision makers from the private and public sectors who share a commitment to social and economic development in Sweden. Its aim is to improve the basis for rational decisions on major social and economic issues, by promoting social science research and stimulating public debate.

The SNS Democratic Audit of Sweden

The aim of the Democratic Audit is to actively contribute to a constructive, objective debate on the basic preconditions for democracy by means of a wider discussion of the concepts, analyses and the political science research on democracy. The Democratic Audit of Sweden consists of independent scholars who have been invited by SNS to assess the state of Swedish democracy.

Translation from Swedish.

Mediernas valmakt.

Demokratirådets rapport 2006.

Olof Petersson, Monika Djerf-Pierre, Sören Holmberg,
Jesper Strömbäck, Lennart Weibull

Translated by Charly Hultén

ISBN 13: 978-91-85355-86-0

ISBN 10: 91-85355-86-0

SNS Förlag, Stockholm 2006

© 2006 by the authors and SNS Förlag

Graphic design by Patrik Sundström

Contents

Foreword 7

1. Media, Parties and Voters 9

Political communication 10

Media and politics in contemporary democracies 13

Media and election campaigns in Sweden 22

A triangle drama 43

2. The Media's Campaign 49

Elections to the Riksdag: good news 54

Partisan bias in campaign coverage 67

Medialized election coverage 71

The struggle for control over the agenda 83

3. The Parties' Campaign 89

Political parties in medialized democracy 90

Americanization? 102

The evolution of election campaigning 118

4. The Voters' Campaign 120

The growing importance of campaigns 121

Media exposure 125

Voters' contacts with the parties 134

Knowledge improves, but only slightly 139

What voters do and think 144

What is need not always be 148

5. Internet: A New Town Square? 150

The first Internet election 151

Alternative and new public spheres 152

Internet and democracy 159

A new kind of campaign? 164

6. Election Campaigns in the Future 167

Voters 167

Parties 169

Media 171

Election campaigns 173

References 176

Foreword

SNS, Studieförbundet Näringsliv och Samhälle (Centre for Business and Policy Studies), is an independent, non-partisan network of debaters and policy-makers in the private and public sectors. SNS commissions and carries out research, publishes reports and books and arranges colloquia and conferences with a view to informing and stimulating public discussion and rational policy-making relating to social issues.

The SNS Democratic Audit of Sweden (SNS Demokratiråd) consists of independent scholars who, at the request of SNS, present theoretical and empirical findings relating to democratic norms and practices. The Audit's annual reports seek to stimulate constructive and fact-based discussions of the premises for democratic processes and institutions.

For more than a decade now, the Democratic Audit has discussed representative democracy and the extent to which voters are able to influence their society via the ballot box. The topic of the annual report for 2005 was »the integrity of mass media«. Now we have the opportunity to integrate the two themes: the media's roles in election campaigns is in focus here.

The members of the Democratic Audit 2006 are Monica Djerf-Pierre (Associate Professor, Göteborg University), Sören Holmberg (Professor, Göteborg University), Jesper Strömbäck (Professor, Mid Sweden University), and Lennart Weibull (Professor, Göteborg University) under the chairmanship of the undersigned, who has both contributed to and edited this volume. The report is a team effort; we have all contributed to the text and assume collective responsibility for the conclusions in it.

Certain special studies conducted expressly for this report are available in Swedish on the SNS website, www.sns.se. The Swedish edition of the book went to press in March and was

published in June 2006. The English translation is true to the original, with only minor adjustments and clarifications for the benefit of foreign readers. General background information on Swedish media and politics may be found at www.sweden.se.

Several people and organizations have contributed to this report by offering facts and criticism. Observer Sverige AB, a corporate intelligence firm, has made data on media content available to us for secondary analysis. We should like to express our thanks to all the staff at Observer, and especially the reference group that is attached to SNS Media Forum (SNS Medieforum).

The Democratic Audit has been funded by grants from the companies and agencies that are represented in the Media Forum reference group. We should especially like to acknowledge the grant extended by Carl-Olof och Jenz Hamrins Stiftelse.

The Democratic Audit has enjoyed full academic freedom. As is the case for all SNS publications, the authors bear sole responsibility for the contents.

We have special cause to acknowledge the contributions of our many predecessors, each of whom has enriched our understanding of the nature of election campaigns. Should we mention any one of them by name, it is Professor emeritus Jörgen Westerståhl, who, together with Bo Särilvik, pioneered Swedish research on elections, voters and the media. Their first report, *Svensk valrörelse* [Campaign in Sweden] appeared precisely fifty years ago.

As we were putting the final touches on the manuscript we learned of Jörgen Westerståhl's passing. This book is dedicated to his memory.

Stockholm in June 2006

OLOF PETERSSON

1. Media, Parties and Voters

»In early days at least, political rallies represented the classic form of election propaganda. Radio, and even the printed word, have without a doubt taken over the rally's former role as principal instrument of propaganda during the election campaign itself.«

So concluded a pioneer study of Swedish election campaigns (Westerståhl & Särilvik 1956:197) fully a half-century ago. Subsequent developments have most definitely borne that conclusion out. Direct meetings between candidate and voter have gradually been supplanted by indirect communication via media of various sorts. Radio and the printed word have been joined by television and numerous new electronic media. The change has been so comprehensive that we can no longer describe the media merely as »instruments of propaganda«, a term that implies a role limited to conveying the parties' messages to the electorate. Journalists of today are active communicators and have gradually transformed both political rhetoric and how the parties go about doing their work. A study of the role of the media in election campaigns can contribute to an understanding of the changes that have occurred in representative democracy as practiced in Sweden.

Political communication

In a historical perspective contemporary election campaigns in many ways seem new and different, but in terms of certain fundamentals at least, continuity is actually the more dominant characteristic. Ever since people first began to make collective decisions and choose leaders there has been political communication.

Meeting face-to-face

Quintus Tullius Cicero is often dubbed the world's first political consultant. In 64 BC he composed some good advice for his brother, Marcus Tullius Cicero, who was running for election to Consul in Rome.

There are two paths to success, writes Quintus: the support of your friends and the favor of the people. A candidate should study his enemies and opponents, know their motives and who their friends and allies are. To gain the favor of the people, a candidate needs to address each one he meets by name, he should be friendly and agreeable, listen to what they have to say, cultivate their respect and nourish their hopes.

The prerequisite to success in an election is communicative skill as well as having something to communicate. In the Ciceros' day the candidate was able to meet his voters face to face.

Indirect communication via the media

In small communities physical convocations and the spoken word can suffice, but as soon as a polity grows to encompass many people or large areas or long periods of time, there arises a need for written documents and other media. Through the centuries, political communication has made use of different technical solutions: from smoke signals to pamphlets,

handbills, posters, radio broadcasts, public address systems, and websites.

Mass media define a special epoch in the history of political communication. They emerged at roughly the same time as general suffrage and modern political parties. Mass-distributed newspapers and, later, the broadcast media were not only prerequisite to large-scale representative democracy, they became an integral part of it. The first studies of voting behavior and mass media of the 1950s are interesting, as they mirror an era when mass media were assuming an increasingly important role in election campaigns and were beginning to supplant meetings, rallies and other earlier modes of political communication.

That media in general, and mass media in particular, are important in election campaigns is an old, established truth. The intertwining of media and politics has a long history in Sweden.

Newspapers began trying to influence opinion only shortly after the introduction of freedom of the press. *Aftonbladet*, founded in 1830 by the Stockholm industrialist, Lars Johan Hierta, was highly instrumental in expanding the freedoms and rights of the Swedish people. The struggle for general suffrage during the second half of the century bore close ties to the influence of the Liberal press of the time. Even before every man had the vote, the news reporting of local newspapers was highly politicized and partisan. The founding of Social Democratic newspapers all over Sweden in the early years of the twentieth century was generally motivated by a perceived need for a *vox populi* and an outlet for the views of organized labor in each and every constituency, not least for the sake of political campaigning. The same rationale lay behind the founding of the Agrarian Party's papers a decade or so later.

With general suffrage the importance of the mass-distributed press as an instrument of opinion formation grew. Radio

came on the air in the 1920s, but decades would pass before the medium started to play a role in party politics and election campaigning. Television, introduced in the 1950s, was similarly cautious in its approach to politics. Television had been on the air a couple of years before the first daily newscasts were aired, and even more time passed before it carried the first items of domestic political news.

Journalist-steered mass media

Only in the 1960s did radio and television introduce independent journalistic coverage of election campaigns. The media became less predictable. The broadcast media became more independent, and journalists began vying with politicians for the power to set the political agenda during election campaigns. In the 1970s and 1980s, newspapers followed the broadcast media's lead, becoming more assertive, first in news coverage, then in opinion columns and commentary, as well.

The election campaigns of recent decades have thus taken place under the influence of journalistically steered media. The change in the role of mass media was among the factors behind the parties' interest in developing new campaign strategies. Nowadays, visibility in newspapers, radio and television is more important to politicians than meeting the voters face to face. Political meetings and rallies are still held, but the underlying motive is often to attract media coverage.

Changes and variations

Does this mean »the End of History«, or are we simply entering a new phase of political communication? Are the new interactive media, like the web, blogs and sms, forming a new infrastructure for democratic communication?

History has shown that new means of communication can

change power relationships, and very quickly. During the golden age of mass media, media owners and publishers acquired considerable influence over opinion formation. With the emergence of modern news journalism, a protracted contest between politicians and journalists ensued as to who would set the agenda in election debates.

International comparisons often put prevailing conditions in one's own time and place in relief. On the whole, political communication in democratic countries reveals mixed patterns of similarities and differences. Some aspects of the political process, like party competition and election polemics are part of the essence of democracy and are fairly universal. But there are also national characteristics that make election campaigns and the interplay of politics and the media quite different from one country to the next.

Media and politics in contemporary democracies

How media interact with politics in a country depends on a number of factors. These have to do with the social and political systems and the media, as well as the traditions that have developed over time and are expressed in what we call the political culture. History shows that social change and developments in the media go hand in hand (McQuail 2005). The media have been formed by developments in politics, the economy and technology. Meanwhile, the media have also influenced society and, not least, politics.

Ideas, too, have influenced the relationship between media and the political sphere. The most important distinction in views on the social role of the media concern how they relate to the powers of state. The classical liberal views that characterize the Anglo-Saxon tradition emphasize the importance of the media's independence, whereas authoritarian systems

characterized by traditions of state control view the media as instruments for the exercise of power.

Three models

Media researchers Daniel Hallin and Paolo Mancini have developed a schema for systematic analysis of the political conditions under which mass media operate (Hallin & Mancini 2004). Their studies have focused on the similarities and differences between systems of political mass communication in Western Europe and the USA.

Common to both regions is a widespread commitment to the ideology of social responsibility combined with a conception of the media as independent social forces (Hadenius & Weibull 2005). The countries also share well-established democratic traditions, but differ with respect to the relationship between the media and politics. To gain a better understanding of these differences Hallin and Mancini have analyzed characteristics of both the media systems and political systems in the various countries.

Media systems are compared in terms of four dimensions: »(1) the development of media markets, with particular emphasis on the strong or weak development of a mass circulation press; (2) political parallelism, that is, the degree and nature of the links between the media and political parties or, more broadly, the extent to which the media system reflects the major political divisions in society; (3) the development of journalistic professionalism; and (4) the degree and nature of state intervention in the media system« (Hallin & Mancini 2004).

As for the political system, the analysis focuses on factors that influence how media function. One such factor is historical tradition and the degree to which the political culture is characterized by either conflict or consensus. Another is the nature of government, i.e., whether a country is governed by

majority rule with a well-defined opposition or is governed more or less by consensus within broad coalitions. The status of political parties and the role of the powers of state are other important factors, as are citizens' attitudes toward authority, authorities, and groups in power.

On the basis of these dimensions Hallin and Mancini define three different media systems: the liberal model, the polarized pluralist model and the democratic corporatist model. They go on to place individual countries in a triangular field between the three systems (Figure 1.1).

The liberal model characterizes the relationship between media and the political sphere in countries like Great Britain and the USA. Countries associated with this model have rel-

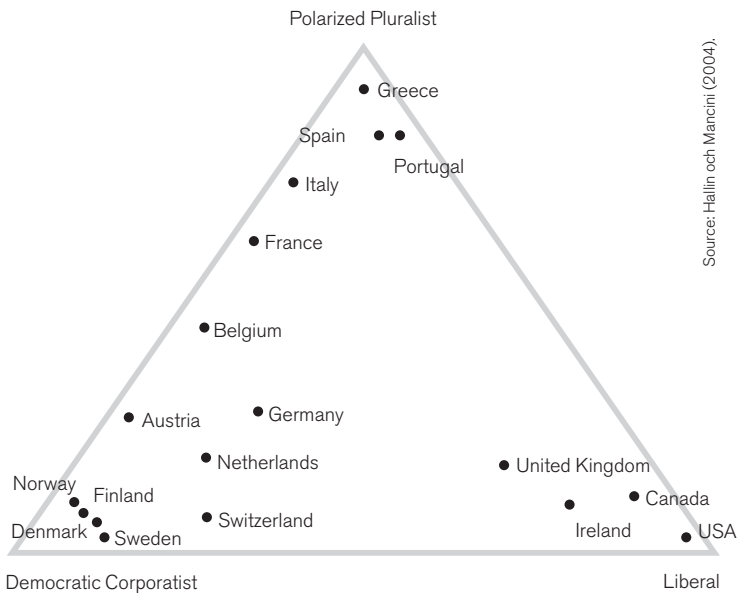

Figure 1.1 Media and politics: three models

atively long histories of democratic rule and rather few political parties. Majority governments are the rule. Pluralism in the political system relates more to the individuals elected to office than to party blocs. The role of the state is relatively limited, particularly in the area of social welfare. Laws have a high degree of legitimacy. As for the media, the press, although losing ground, occupies a relatively strong position. With few exceptions the media are privately owned commercial ventures, and editorial pluralism is more prevalent within individual media than between media. Journalists enjoy a high degree of autonomy, which is rooted more in tradition than in formalized rules. The USA typifies this model.

The polarized pluralist model is common in southern Europe. The countries associated with this model have relatively short histories of democratic rule. Political parties play an important role; both majority governments and broad coalitions are common. The state plays a relatively active role. At the same time, the legitimacy of the legal system is undermined by a tradition of clientelism, whereby personal 'connections' can de facto outweigh the letter of the law. As for the media, newspapers have relatively weak penetration among the citizenry; there is, however, a politically oriented elite press. Close relations prevail between the media – the press and broadcast media alike – and the political sphere. The media have strong party allegiances, which results in considerable pluralism in the media system. Italian journalists are characterized by a weaker professionalization and operate within the bounds of a media system that is integrated into the political system. Government influence over the media is relatively strong, and state interventions do occur. Italy epitomizes the polarized pluralist model.

The democratic corporatist model is common mainly in northern Europe, and particularly in Fenno-Scandinavia. These countries have long histories of parliamentarism, and politics is consensus-oriented. The parties, alongside other

social groups, occupy a strong position, and the system might be characterized as 'organized pluralism'. Government plays an important role in the economy, particularly in the area of social security and welfare. The rule of law is well-established. With respect to the media, newspapers have a dominant position, in terms of both tradition and readership. Public service radio and television also occupy a central position. There have also been rather close ties between the media and politics, organizationally as well as in terms of content, although party ties have relaxed in recent decades. Journalists enjoy a marked degree of autonomy, and there is an institutionalized system of self-regulation in the case of print media. Government exerts some influence over the media structure in the case of public service broadcasting and press subsidies, but there is a strong commitment to freedom of the press, both codified in law (constitutional law in Sweden) and in prevailing ideology. The countries of Fenno-Scandinavia typify this model.

The differences between political communication systems have their roots in social and economic differences. All attempts to fit political communication systems into typologies of a few categories are necessarily simplistic. This becomes especially apparent when deciding the position of the various systems in the triangular field. There are few 'pure' cases, and the boundary between polarized pluralism and democratic corporatism is somewhat fluid. The localization of Great Britain in the liberal model is especially problematic inasmuch as the BBC is the archetypical public service broadcasting institution.

The points in the triangle may be taken as measures of the relative strength of the parties, government and the market, respectively. They indicate which forces determine the relationship between the media and the political sphere. Characteristic of political life in the USA is that the market exerts stronger influence than either government or the parties. In

the countries of southern Europe the parties are stronger than government or the market; here in the North, the government is stronger than the parties or the market.

Three kinds of election campaigns

‘Americanization’ is a term that often comes up in discussions of the changes that have occurred in Swedish election campaigns and what we may expect in the future. It is often pointed out that certain tactics have been imported from the USA and that American consultants have been hired to advise one or the other party. In a later chapter we will examine to what extent ‘Americanization’ is fact or fiction, but even Hallin and Mancini’s international overview gives cause for thought.

The American model is hardly the only alternative or the only scenario for future developments. The picture is far more complicated than that; Sweden in relation to the USA is only one of many possible comparisons. It is hardly necessary to cross the Atlantic to find possible alternatives and possible futures. Polarized pluralism, for example, represents a possibility that cannot be discounted.

For the sake of concretion we have chosen to illustrate each of the models with a single country. That we have chosen the USA to represent a liberal, market orientation is hardly surprising. A country that lies near the extreme of the polarized pluralism model is Italy. The choice of Sweden as the epitome of the democratic corporatist model is in line with Hallin and Mancini’s assessments.

The United States of America. The North Atlantic Liberal model is based on quite special circumstances. One feature of the political culture is the weakness of the party organizations: American parties are like umbrellas, under which a variety of candidates operate and a broad range of opinions and values coexist. It is the candidates, not the parties,

who run for office and who decide which issues are emphasized. That the elections are based on single-seat constituencies underlines the focus on the individual candidate even more. The parties' candidates for the office of President are selected through a complex process that in many states entails so-called primary elections. Primary election campaigns are started more than a year ahead of the final Election Day; unofficial campaigning starts even earlier.

As a consequence, American presidential campaigns are long, person-oriented and very expensive. In the presidential election of 2004 the campaigns for Republican George W Bush and Democrat John Kerry each cost more than a billion dollars (Ceaser & Busch 2005). In addition there are, every second year, all the expenses for 435 campaigns to seats in the House of Representatives, and to one-third of the 100 seats in the U.S. Senate.

That running for national office costs so much has several explanations. First of all, there is the size of the country and many states and the long periods of time involved, but a third contributing factor is the fact that campaign communication mainly takes place via television spot advertisements on commercial television (Kaid 2004). Although television news departments do cover the campaigns, the key to winning an election is effective TV spots. TV-spots are expensive, and prices continue to rise, which means steadily rising campaign costs, as well.

The dominance of television advertising in American election campaigns has to do with the overall nature of the media system, which is one of the most thoroughly commercial systems in the world – in terms of both ownership structures and ideology (Croteau & Hoynes 2001, Hamilton 2004). The links between media and the parties are also relatively weak. Public service television exists, but is only marginal; ratings for public service channels – which are local, but nationally affiliated – hover around 2 per cent.

Most American journalists equate objectivity with being as fair as possible in reporting the different views on an issue (Patterson 1998). To avoid accusations of bias or partisanship the media strive for objectivity, neutrality and a critical perspective on the campaigns. Presidential candidates therefore find it difficult to reach voters via news columns and newscasts and are forced to invest in paid air time. The importance of TV spots is reinforced by the fact that television dominates Americans' media consumption and that in election years no more than about 15 per cent of news items in mainstream newscasts have to do with election or campaign news (Graber 2006).

American campaigns tend to have a negative tone, with attacks on the opposing candidate dominating paid advertisements. The degree of diversity of opinion that prevails depends on journalists' choices and on who has the money to buy air time. As a rule, diversity of opinion, even in news reporting, is reserved for the most dominant and well-to-do contenders. New parties and new candidates find it very difficult to make themselves known unless their campaign coffers are filled to the brim.

Italy. In election campaigns the Italian media system exhibits most of the characteristics of the polarized pluralist model. The daily press is highly partisan, with close ties to the respective parties – in terms of both content and readership. Control over television is also highly politicized. RAI's three public service channels are subject to extensive political steering.

Rules were introduced for broadcasting, and RAI in particular, in 2000. Their aim was to ensure all parties access to radio and television during election campaigns. The rules mainly apply to television, commercial channels included, and set out basic rules of conduct that channels are to observe during the last four weeks before Election Day. The rules also prescribe a moratorium on presenting the results of opinion

polling the last fifteen days of the campaign. The moratorium applies to print media, as well. (For a more detailed account of these rules, see Djerf-Pierre & Weibull 2005.)

The trouble is that no one can be absolutely sure how the rules will be applied. Italian politics is constantly in flux, coalitions being forged and dissolved all the time. Virtually everything is negotiable. During his time in office Prime Minister Silvio Berlusconi demonstrated considerable skill in manipulating the system to his own advantage.

Paid political advertising is prohibited during election campaigns. Instead, the channels are required to make air time available to candidates free of charge. Candidates may air three-minute presentations of their own making. In the case of newscasts, coverage the last four weeks before the election must be evenly balanced. If one politician is allowed to voice an opinion, that opinion must be balanced by opposing points of view. In the case of public affairs programming there are complicated rules to the effect that spokespersons for the various parties shall be allowed air time in proportion to the party's representation in Parliament. The law also forbids politicians to appear in entertainment programs the last four weeks of the campaign. The system of rules is constantly under attack. Not least Mr Berlusconi has been discontented, as he feels the rules work against him and his coalition.

Thus, an Italian election campaign is characterized by a close intertwining of politicians and media. Given a northern European or American frame of reference, the Italian system may seem old-fashioned, not least because partisanship is practically institutionalized through the ties between press and the parties and the rules for political access to radio and television. The result is that the public, the voter, cannot receive a balanced or impartial account of what is happening from one newspaper or one TV channel, something that is normally taken for granted in modern northern European and American contexts. But if we instead take our point of

departure in the value of many ideas and points of view being expressed in the course of a political campaign, we find that the Italian system has an advantage in that the regulations imposed mean that media coverage as a whole reflects the entire spectrum of political parties.

In the Italian system political institutions stand strong vis-à-vis the media. In view of the fact that independence of the political sphere is a criterion of professionalism of journalism in the northern European and American systems, it may come as something of a surprise that the symbiotic relationship between press and politics poses no problem to Italian journalists' notion of professionalism. In Italy, too, leading journalists maintain a strong professional stance, but that does not necessarily mean that they will critically and dispassionately examine political events in an autonomous fashion. Instead, their principal ambition may be to generate debate and political understanding through thorough critical analysis.

Media and election campaigns in Sweden

In international comparison Sweden appears to typify the democratic corporatist model of the northern European type. Political communication arises out of powerful organizations with historically close ties to the media. These party ties have relaxed appreciably in recent decades, which has also had an impact on how election campaigns are conducted.

From a historical perspective election campaigning in Sweden, as in most other industrial societies, correlates closely with the development of mass media. Since their first appearance in the latter half of the eighteenth century and through the nineteenth century, Swedish newspapers were closely related to the political sphere, if not outright partisan. Most were founded with a combination of publicistic, political and

commercial ambitions. In early days it was difficult to distinguish news content from the politicking. The newspaper, *En ärlig svensk* [An honest Swede], published before the Riksdag [parliamentary session] of 1755, is often identified as Sweden's first party paper (Hadenius & Weibull 2005).

Even if there were exceptions, most newspapers were started with a view to fomenting and influencing political opinion. In most cases the figures behind the paper were of the liberal persuasion. Newspapers often engaged Members of Parliament to write for them, albeit anonymously as a rule. *Aftonbladet* was to be a mainstay of the campaign against reactionary constraints on press freedom imposed by the Crown in the 1830s and 1840s.

That the press exerted an influence on political campaigning is therefore hardly surprising. In his survey of Swedish election campaigns 1866–1988, political scientist Peter Esaiasson points out that even early election campaigns made use of newspapers to mobilize their supporters, even though newspapers of the time had limited circulation. In the campaign of 1869 liberal newspapers overtly campaigned for the party's candidates, and other parties, too, were very active. A contemporary commentator described the election of 1884 with the words, »It was all done American-style.« He was referring to the use of advertisements and campaign staff who worked door-to-door, urging voters to vote for their candidate (Esaiasson 1990:75).

The election campaigns of the late 1800s and early 1900s were, of course, not really comparable to campaigns of today. Voting was restricted and voters voted for individual candidates rather than parties, and elections were also local affairs, not even held on the same day. The situation began to change in the 1890s, however, through a greater emphasis on the national party organizations and standardization of Election Day nationwide (Johansson 1977). The changes were outgrowths of industrialization and its social and eco-

conomic consequences. The changes implied changes in political communication, as well, and here the party press played a central role.

The party press

In election campaigns of the years before and after the turn of the past century, newspapers of the same party color began to work in concert. Many editors-in-chief were politically active and had close contacts with members of Parliament, if they were not MPs themselves. The liberal press pioneered the change and also campaigned for expansion of voting rights (Vallinder 1962). Several Conservative papers adopted a common strategy in the campaign of 1896. The Social-Democratic press, too, developed in the provinces about this time; these papers were founded with election campaigning explicitly in mind and normally aimed at coverage of a constituency. Their role was to complement the labor movement's agitators. Of the 22 Social-Democratic newspapers founded between 1899 and 1909, half were started in election years (Hadenius, Seveborg & Weibull 1968).

The advent of a party press changed the character of election campaigns. Election news tripled in volume between 1896 and 1908, and newspapers' interest in politics contributed to the development of a truly national political arena and the growing importance of parties as institutions (Johansson 1977). In 1908, voters still chose between candidates rather than parties in single-seat constituencies, but newspapers began to devote attention to issues of national scope and to carry the contents of debates between the parties. Figure 1.2 summarizes newspapers' contribution to this development. The Social Democratic press was the prime motor in this regard. The party and the trade union movement were very strategic in their use of newspapers to agitate and cultivate opinion (Hadenius, Seveborg & Weibull 1970).

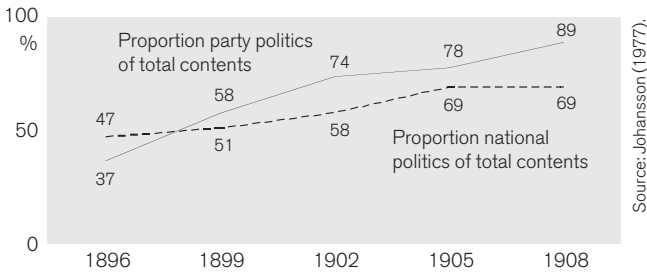

Figure 1.2 National politics and party politics in Swedish provincial press 1896–1908

Percentage of newspapers' total election coverage. Data based on a study of between 93 (1896) and 114 (1908) newspapers each

year. Total inventory of election coverage one month before the elections. *Source:* Johansson (1977).

Characteristic of newspapers election coverage in early years was the practice of extolling the virtues of one's own candidates but totally ignoring their opponents. The campaign of 1914 in Gävle, a town that had three local newspapers, is a prime example: Those who read *Gefle-Posten* could read that the Conservative candidate, Captain Indebetou, had held a »most excellent« speech at a Conservative meeting in town, whereas readers of the Social Democratic *Arbetarbladet* were told nothing about the Conservative meeting, but could read an enthusiastic report of the Social Democratic agitator Fabian Månsson's speech to participants in a rally held in Boulognerskogen, a city park. Liberal *Gefle Dagblad* mentioned neither Indebetou's or Månsson's speech, but published an appel from the Liberal Party, and readers were urged, in both news columns and paid advertisements, to vote Liberal on Election Day (Hadenius & Weibull, 2005:292).

In retrospect, the former half of the twentieth century stands out as the 'golden age' of the party press in Sweden. In these years it was natural for every newspaper to have a par-

ty affiliation and to use its columns to support its party during election campaigns.

Although coverage was less one-sided than in early days, the papers' partisanship was striking. Figure 1.3 shows the extent to which two morning newspapers favored their respective parties. Nor did partisanship pose any problem to journalists inasmuch as journalists generally had the same political sympathies as the paper they worked for, and the paper's editors were often active in the parties, even representing their party in political bodies (Söderström & Ahrnstedt 1956; Kronvall 1975).

Although partisanship was the rule throughout the daily press, there were considerable differences in the conditions under which the different groupings operated. liberal newspapers, and to some extent Conservative papers, as

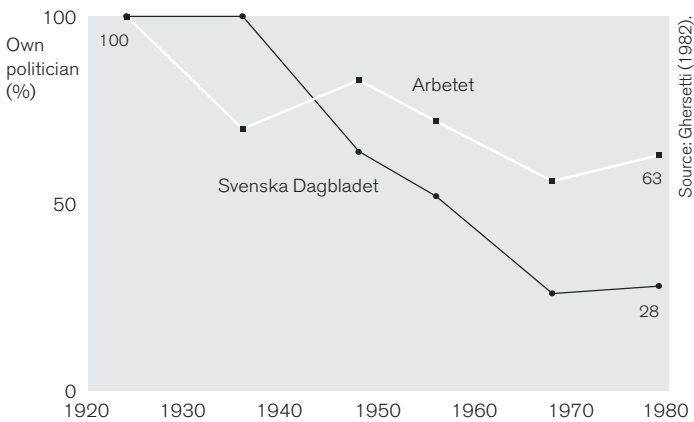

Figure 1.3 Political partisanship in two morning newspapers 1924–1979

Arbetet is Social Democratic and Svenska Dagbladet is Conservative throughout the period. »Own politician« means politician representing

the paper's party. The analysis was performed on between 5,000 (1924) and 19,000 (1979) lines of copy.

well, were given freer rein, especially in economic terms, than Social Democratic and Agrarian Party (subsequently Center Party) papers. The differences would come to play a role in the changes with respect to party affiliation that took place in the 1970s.

New and different campaigns

The introduction of universal suffrage and proportional elections changed the nature of political campaigning. The parties, rather than individual candidates, planned campaign activities. Local campaign meetings were very important, the number of meetings reaching a peak in the 1930s. Campaign meetings were more important for Social Democrats than Liberals or Conservatives, whose direct links to the daily press played a greater role (Esaïasson 1990).

A strong party press, the penetration of which grew rapidly in the first decades of the twentieth century, did not supplant other campaign activities; still, party leadership was becoming increasingly aware of the media's importance. The number of people attending campaign rallies and meetings was beginning to decline. In a transitional period, a hybrid form of meeting-and-media developed: films were produced and screened to attract people to the meetings. These campaign films form a distinct epoch in Swedish election history. In the 1954 campaign, for example, the Agrarian Party produced a film entitled »What our part of the country needs« and the Social Democrats produced what was to become the classic Swedish campaign film: »Tax-Free Andersson«, featuring stars of the Swedish stage and screen, Stig Järrel and Gaby Stenberg.

The increasing importance of mass media did not mean that other forms of campaigning were abandoned. Leaflets and brochures were more important than ever, even as the party meeting started to decline. Newspapers, still par-

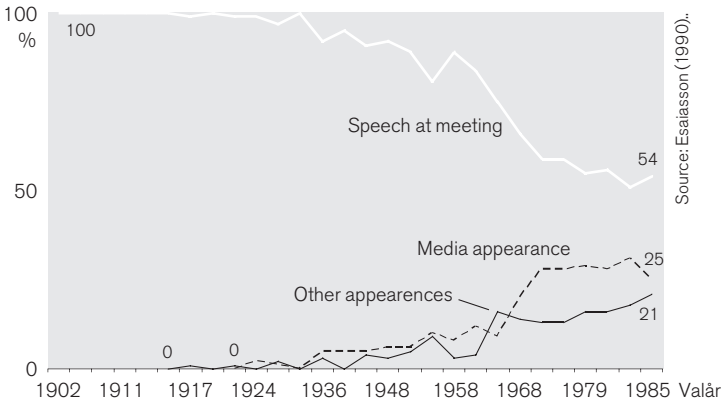

Figure 1.4 Party leaders' public appearances in election campaigns 1902–1985

The graph shows how the party leaders have made use of different forms of public appearance in their campaigns. The category »speech at meeting« includes even short talks/exhortations at rallies and visits to workplaces. »Media appearance« means participation in public service election programs and announced press

conferences. Informal contacts and personal interviews with individual journalists are not included in the material, nor are the politicians' articles, position papers etc. »Other appearances« refers to visits to workplaces, boat outings etc. The percentages are calculated on the basis of the party leaders' total campaign appearances.

tisan, remained an important tool for opinion formation. The big changes came in the 1960s, when television entered into Swedish homes on a large scale (Esaiasson 1990). Contacts with the media became increasingly important to party leaders, while formal speeches or talks delivered in person at meetings began to recede into the background (Figure 1.4).

Controversial radio coverage

The advent of radio in Sweden in 1925 did not have any immediate impact on political news coverage (Djerf-Pierre & Weibull 2001). The government was, however, aware of the potential of the medium, and from the start radio was regu-

lated according to principles that remain on the books to this day. Radio should operate in the service of the public, and programming should observe standards of factuality and impartiality.

That radio could become a political tool was clear to all, even during the trial period before AB Radiotjänst, a public service monopoly company, came on the air. In early 1924, the leading Stockholm newspaper, *Dagens Nyheter* (Liberal) sought to transmit coverage of the budget debates from the Riksdag. The idea had won the approval of the Speaker of the Lower House, but shortly before the debate, the transmissions were cancelled because some MPs had objected (Elgemyr 1984). A proposal from *Dagens Nyheter* later the same year to arrange broadcasts of political debates got a mixed reception, but after some negotiating a debate of sorts – it was more like a multi-party election meeting – was transmitted September 15, 1924 (Esaiasson 1990). The program was very nearly ‘the last word’ in the campaign, being transmitted only four days before Election Day.

Political debates on the radio were more the exception than the rule, however. The closest thing to them was a recurring program, »The Riksdag Chronicle«, which came on the air in 1927 and continued until 1940. The »Chronicle«, which had the same editor from start to finish, was a carefully balanced digest of recent interventions in the Houses of Parliament. Top management of the radio company was of the opinion that radio should not broadcast debates, which were considered the province of the press. The first direct transmissions from a Riksdag debate occurred as late as 1947 (Djerf-Pierre & Weibull 2001).

AB Radiotjänst was apparently unsure about how to deal with election campaigns. In advance of the elections of 1928, which were surrounded by considerable political tension, company management decided not to give air time to partisan messages or campaign speeches and the like, but to lim-

it election coverage to rules regarding voting procedure and general election information (Esaiasson 1990).

The election of 1932 was the first time Radiotjänst arranged a campaign debate. It was a controversial decision, not easily reached. The original idea was to let the respective party leaders speak about their parties' platforms, on the condition that their scripts would be approved by Radiotjänst beforehand. The idea was broached with the party leaders, several of whom were reticent. The problem was that the demands of impartiality meant that Radiotjänst might have to give the Communists air time, which some parties found objectionable. At that juncture the company turned to the Program Council, an independent advisory board, for advice. The Council's members turned out to be in favor of political broadcasts and ruled that the requirements of factuality and impartiality posed no hindrances to discussions of current issues, provided the medium was open to all points of view. Despite the Council's encouragement, Radiotjänst scrapped the idea and planned to replace the party leaders with speakers such as high-profile political scientists Nils Herlitz and Herbert Tingsten.

This idea was not well received by the parties, and Radiotjänst was forced to go back to the original idea of a debate. The result was a debate on the topic, »The parties and the political crisis«, aired on September 12, 1932. Representatives of all the political parties were gathered in the studio. Although no party leaders took part, the debate was an 'all-star' affair, with leading politicians of the day: Ernst Wigforss, Axel Pehrsson in Bramstorp, Nils Wohlin and Ture Nerman (Esaiasson 1990). The program was well received, among politicians and listeners alike. The 1932 party debate established campaign coverage in the medium. From then on, radio carried debates and presentations of the political parties, the air time reserved for the programs expanding with each successive election.

Campaign coverage was careful to observe the cardinal rules of impartiality and factuality. These ideals, instituted from the start of Swedish broadcasting, still apply (Weibull 2006).

Gradually, radio journalists took a more active role in the coverage. A major change took place in 1946, when the party presentations were replaced with interviews. The change, motivated by a desire to make the programmes more interesting, was made with the consent of the parties. The parties were allowed to choose the interviewers, the choice generally falling on op-ed journalists working for papers affiliated with the respective parties. The discontinuation of party presentations, important in principle, aroused little debate (Esaiasson & Håkansson 2002). Thanks to the existence of a party press, and thus numerous journalists who were reliably loyal to the party, the change posed no threat.

The 1950s saw a major change in the character of the Swedish press. The tabloid *Expressen*, founded in 1944, introduced a new, popularized style of journalism patterned after Anglo-Saxon models. Over the course of the 1950s and 1960s the nationally distributed evening tabloids were enormously successful. Meanwhile, a good number of local newspapers went out of business. The wave of newspaper failures in Sweden meant that a growing number of communities were served by a single surviving paper. Papers' local monopoly status implied a significant change in the conditions for local newspaper reporting. Although the news columns started adapting to the new situation, in most cases editorial opinion remained partisan. The big change came with the entry of television into people's living rooms.

Enter television

When one studies the pioneer work done on election campaigning from the 1950s, what is particularly striking are the phenomena that are self-evident today, but were absent then. Fifty years ago television played no role in Swedish politics. Another development in this period would also have consequences for politics in general and campaigning in particular for decades to come (see further Esaiasson & Håkansson 2002, and Djerf-Pierre & Weibull 2001): Up until 1956, radio election campaign coverage had taken place in consultation with the parties. But then, the so-called »veto conflict« occurred and transformed political reporting. As a consequence of the conflict broadcast journalism advanced its positions once and for all.

The veto conflict arose when journalists questioned an established practice in broadcast news reporting, namely, the norm that each and every program should be balanced. De facto the principle meant that if one side of a political issue refused to participate, radio could not bring the issue up. In other words, the uncooperative party had the power of veto. In 1956, the editors of public service radio's news program, *Dagens Eko*, broke with tradition and carried an item with the comments of Liberal Party and Conservative leaders on the newly forged coalition between the Social Democrats and the Agrarian Party, even though the Social Democratic Prime Minister had refused to take part. The editors had put news value above established practice. This audacious move aroused heated controversy, and complaints were filed with the Broadcasting Commission, an independent body charged to review the performance of public service broadcasters. The Commission sided with *Dagens Eko*; overnight the parties lost their ability to stifle debate by non-participation (Djerf-Pierre & Weibull 2001).

In the case of television change came more gradually. When public service television started regular service in 1956, news

Domestic politics makes its television debut

The first Swedish television newscast, *Aktuellt*, was aired on September 2, 1958. The transmission was of a style and format that would be characteristic of *Aktuellt* for some years to come. The program was led by an 'anchor' who presented the items and read wire service copy. Bulletins and brief filmed reportage, either commented on from the studio or accompanied by a recorded speaker's voice, predominated. The tone of the program was correct, factual and neutral. Interviews, to the extent they existed, were generally quite long, interviewees being given ample time to develop their thoughts without interruption.

It is striking how little coverage of domestic politics the transmissions contained. Neither party politics nor Riksdag proceedings were reported. What coverage there was – and here, too, only on exception – had to do with the work of the Cabinet. The first item in *Aktuellt* that had to do with domestic party politics was aired January 8, 1959. It was about a proposed obligatory pension scheme, and a letter that the Government had written to the Liberal Party leader, inviting the party to negotiations. The item was introduced as follows: »Prime Minister Erlander has invited the Liberal Party to discuss the issue of the proposed pension scheme. The invitation was extended in a letter to Professor Ohlin, which reads in part: The question of an obligatory supplementary pension has been put to the people in an advisory referendum as well as in the general elections of 1958. On these two occasions a substantial majority of the people have expressed a desire that such a supplementary pension scheme be introduced. It is the Government's view that the pension issue should be resolved in a positive fashion as quickly as possible. ...«

Hearing the item read on television provoked the Liberal Party leader, who immediately called the *Aktuellt* offices. Later in the program his reaction was reported in an extra item, which started: »Five minutes ago, Liberal Party leader Professor Ohlin called *Aktuellt* and said that he had made it clear to the Prime Minister that any democratic resolution of the pension issue should respect the entire [spectrum of] opinion that was expressed in the referendum and the pension election last Spring. On both these occasions the Government's proposal was supported by less than half of the votes cast, a circumstance that the Prime Minister's statement ignores«

The reasons why there was so little coverage of domestic politics on television are several. First, the *Aktuellt* staff did not have a political reporter, so that no one felt any particular responsibility to cover political news. Secondly, domestic politics was an area that company management considered sensitive. Television news also had limited access to the most central political

* It is in any case the first example that is documented in Sveriges Radio's archives.

arena of the day, the Riksdag. Instead, political coverage focused on election campaigns and televised debates, in which connection rules providing for balance and other agreements as to the form and content of the coverage were worked out in advance in consultation with the political parties.

Source: Djerf-Pierre & Weibull (2001).

1962: TV as town meeting hall

In the weeks leading up to the elections of 1962, Sveriges Radio's program magazine, *Röster i Radio TV*, asked the five party leaders to comment on the new medium, television, »which had turned the entire country into one big town meeting« (nr 36:8–15, September 1962). Their responses are interesting documentation of how politicians of that era pictured election campaigns of the future. Some quotes:

Conservative leader Gunnar Heckscher: »Television has strong suggestive powers, I'm sure. But it is not likely to precipitate any political landslides. We in the Conservative Party will continue to rely on our devoted and determined field workers.«

Center Party leader Gunnar Hedlund: »Radio and television have come to political propaganda-making to stay. I have no doubts that the people of any democratic country will see to it that they do.«

Liberal Party leader Bertil Ohlin: »Politics can be presented to the people more effectively and, with the help of pictures and diagrams, more informatively than through lectures. The daily press will also be complemented in an excellent fashion.«

Prime Minister Tage Erlander, Social Democrat: »Television is important. But I doubt it will replace other media. On the contrary, I think that in time it will stimulate greater interest in political discussions on the radio, in newspapers and magazines, in organizations, and so forth.«

Communist Party leader Hilding Hagberg: »Personally, I don't care much for figuring in television debates, while at the same time, from the point of view of my ideas and my party's interests, I value the opportunity to do so.«

was not a top priority. The company's news program, *Aktuellt*, started in 1958, but the first item of domestic political news was aired first four months later. Political news coverage was confined to election campaigns and debates, where the rules of balance and form and content of the programs were worked out in advance consultation with the parties.

The election campaign of 1960, however, showed that television had emerged as the prime channel of opinion formation for parties and voters alike. A survey undertaken in connection with this election found that election programming reached nine voters in ten. Owners of television sets became the parties' most important target group. Presentations produced by the parties themselves attracted rather few viewers, whereas debates between party leaders were the most popular election programs. Television had become voters' main source of information during the election campaign (Sjödén 1962).

The main bone of contention at this juncture concerned who, the parties or journalistic media, should set the terms for political debate on radio and television, i.e., who should control the political agenda. What issues should be discussed and on whose terms? The parties, for their part, wanted air time on their own terms, a chance to present their program for the electorate. Sveriges Radio, the public service broadcaster, alone on the air waves, argued that news value should decide whether or not a party received coverage. Journalists considered debates that were totally controlled by the parties bad radio and TV; the programs would be entirely predictable and fail to attract an audience. Therefore, they argued, news values should prevail.

Coverage of politics in general and of election campaigns in particular was planned in consultation with the parties in a non-confrontational spirit. Interestingly, this approach would allow Swedish broadcast media to advance their positions relatively quickly and, in an international perspective, rather early.

Within the field of political reporting journalists successively developed their independence in relation to the parties. In the election of 1960 television had taken the initiative from the parties with respect to interviews with the party leaders, albeit the interviewers were still chosen by the parties from their own ranks. In the local government elections of 1966, a minor revolution took place when the interviewers selected by the parties were replaced by three seasoned political reporters from the *Aktuellt* staff: Lars Orup, Gustav Olivecrona and Åke Ortmark. »The three O's« came to symbolize the new political journalism.

The parties had mixed feelings about these developments. To regain at least some initiative they launched a new strategy to influence opinion: they began to arrange numerous press conferences in which they presented new policies and made promises and commented the progress of the campaign to date. For a time, party presentations made a comeback, but in the longer term, television and journalists had clearly taken over. Thus election campaign coverage turned into a struggle as to who – politicians or journalists – would have the privilege of setting the agenda vis-à-vis the voters.

These changes were hardly made against the will of the parties. Sveriges Radio's management was very observant of reactions in the political sphere, and top management deliberated each move. Election coverage continued to be drawn up in consultation with the parties. Whereas it was a 'given' that journalism should remain independent of politics, it should nonetheless be adapted to the rules set out by the Riksdag as well as viewers' needs and interests. Slowly but surely, the positions advanced. For the public service broadcaster it was important to defend its reputation as a source of impartial information and balanced opinion. A dual emphasis on the professionalism of journalists and objectivity in programming constituted the strategy Sveriges Radio used to advantage.

Changes in the media...

Thus, since the early 1970s journalism in all the Swedish media – press, radio and television – have become increasingly independent of political institutions (Djerf-Pierre & Weibull 2001, Weibull 2004). The process is commonly referred to as »the professionalization of journalism«. In 1963, Lars Furhoff, dean of the School of Journalism at Stockholm University, characterized the circumstance that many Swedish newspapers had party political missions as a »betrayal« and found the tradition totally counter to the ideals of the profession of journalism (Furhoff 1963, cf. Weibull 2004).

As we have observed, the broadcast media were the first to emphasize their independence; change in the press came more slowly and was influenced by the papers' ideology in opinion columns and commentary. This is clearly in line with Hallin and Mancini's characterization of Swedish public service broadcasters as decidedly professional and independent of the powers of state. Somewhat paradoxically, professionalism is often measured in terms of the independence of the media rather than by principles of journalistic practice.

The party color of Swedish media has both faded and become more variegated over time. Different political winds predominate in different campaigns, and the tenor of media coverage is no longer as predictable as was once the case (Asp 2003). A more even balance has not implied any reduction in the amount of political coverage. On the contrary, coverage of election campaigns has increased during the interval in question.

Another important change is the launching of new radio and television channels. The introduction of commercial broadcasting in the form of satellite-cable channel TV3 in 1986 and TV4, which was granted a concession for terrestrial transmission in 1991, changed the Swedish media landscape. Interest shifted from the public service broadcaster, Sveriges Television, to the new channels. Whereas the two

SVT channels together had had nearly 100 per cent of total viewing time, their share gradually declined and stabilized in the early 2000s at about 40 per cent. Of the new channels' output entertainment is the most popular. Attention to public affairs programming has declined, whereas viewing of television drama and entertainment has increased. Measured in air time, Swedish television offers more news and public affairs programming today than ever before, but their share of total program output has shrunk (Jönsson & Strömbäck 2007). The new channels also introduced a lighter style of journalism. Early on, TV4 Nyheterna tried an American-style format with anchor-reporter dialogues about the news stories, but the channel reverted to a more traditional format (Asp 1995). In its election coverage, too, TV4 was less formal in its address than SVT. For example, in 1998 TV4 let a trio consisting of a soft-news journalist; a former head of the trade union movement; and a PR consultant with a background in the Liberal Party interview the party leaders (Esaïsson & Håkansson 2002).

The new program concept was not much of a success for TV4. Viewers apparently had greater expectations of SVT's election coverage. Thus, public service television retained its high credibility ratings among the viewing audience, not least because it continued to offer news and public affairs programming in traditional formats. Even if audiences have shrunk, Sveriges Television is the prime focal point when it comes to election campaign coverage.

The fragmentation of the Swedish media system has naturally affected attention to election campaign coverage. The lead stories on principal news channels no longer reach as many viewers. At the same time, the Internet offers a virtually infinite number of news sources, and political blogs offer a variety of takes on politics and trends. Thus, members of the general public now have alternatives to professional journalism, albeit mainstream media still play a dominant role as

sources of information. The political communication system stands on the threshold of yet another period of fundamental change.

...and changes in politics

Swedish mass media's continued attention to politics reflects the continued importance of politics in Swedish society. Just how well-rooted representative democracy is among the Swedish people is more difficult to assess, however, as the trends point in different directions.

As for the commitment to democratic principles, Swedish politics stands on solid ground. Swedish democracy has a long history, and anti-democratic movements operate far out in the periphery. General support for the party system is also relatively strong; the established parties with representation in the Riksdag still attract the great majority of votes in general elections. Nor is there any indication that people's interest in politics might be waning. Moreover, party identification and interest in politics increase in election years (Holmberg 1994, Strömbäck & Johansson 2006).

But beneath this seemingly calm surface there are currents of change that will have an impact on democratic processes in Sweden in both the long and the short term. Voters have become more volatile, their party allegiances less deeply rooted. Up until the mid-1980s the five parliamentary parties totally dominated Swedish politics. The political blocs were relatively well-defined, and although the number of voters who switched party loyalties between elections was rising, the changes generally involved parties within the same bloc. Since then, the party system has become fragmented; new parties have been formed on both national and local levels. SöH föreslår att det förstrukna utgår.

By international comparison participation in elections is high. But compared to the late 1970s, when over 90 per cent

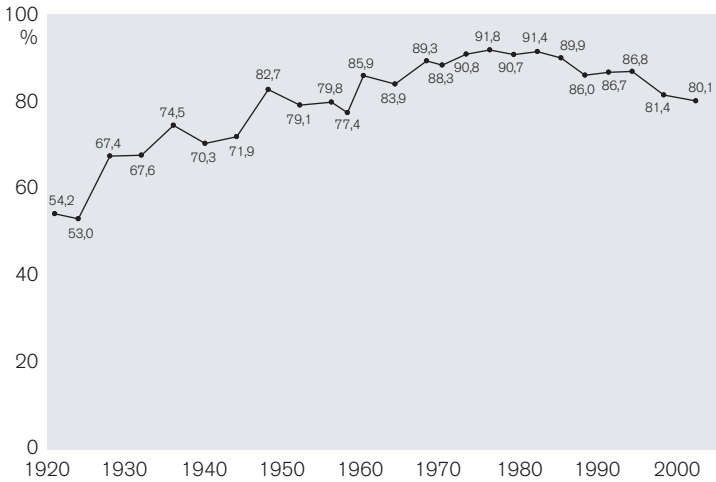

Source: Statistiska centralbyrån, SOS Allmänna valen. www.scb.se

Figur 1.5 Turnout in national elections to the Riksdag (second chamber 1921–1968).

of those eligible cast their vote, the trend has been downward, with polling now resting at about 80 per cent (Figure 1.5). How serious this development may be is an open question, but the Riksdag has declared raising election participation a priority (Bill 2001/2002:80), and a parliamentary Constitutional Commission has been asked to suggest ways to stimulate voting (mandate in dir. 2004:96).

Party membership shows a strong negative trend. Especially the largest parties – the Social Democrats, Center and the Conservatives – are losing members. An analysis based on the parties' own statistics shows that membership in the seven parties represented in the Riksdag today was halved between 1991 and 2004 (Figure 1.6).

Based on the trend between 1991 and 1999, the SNS Democratic Audit made a simple linear projection of the trend and found that given the same rate of decline, party mem-

bership would reach zero in 2012–2013 (Petersson, Hernes, Holmberg, Togeby & Wängnerud 2000). The same operation, but based on the trend between 1991 and 2004, indicated a zero point in about 2017, i.e., a bit more than a decade into the future. The reason the prognosis is longer in the later exercise is that a particularly rapid decline in party membership in the mid-1990s has abated somewhat. The trend these past five years is not as steep, which suggests that the trend may be flattening out.

The changes in the parties reflect a kind of professionalization of politics. Party membership coincides to an increasing degree with the corps of active politicians. »Ordinary« members, members of the public with an active interest in politics, are becoming increasingly rare. Even if those in elected office who are engaged in politics in their leisure (alongside another occupation) are still in the majority, the power in local government has shifted into the hands of professional politicians. Tax-financed allowances to the parties have rendered them less dependent on volunteer efforts, but more vulnerable to decisions taken in the public sector. A good share of the parties' work can be done without mass membership. Citizens, for their part, have many alternative ways to try to influence society around them. But certain of the parties' functions become more difficult as membership declines, not least the recruitment of candidates and opinion formation among the public at large (Petersson 2005).

In any representative democracy – and particularly in one having the ideal of democracy based on popular movements – political parties play a vital role as links and channels of communication between the electorate and their elected representatives. As party membership shrinks, so does the interface between the parties and the people. The importance of mass media for political opinion formation may have a variety of explanations, including both factors relating to the ways the media work and factors relating to the political sys-

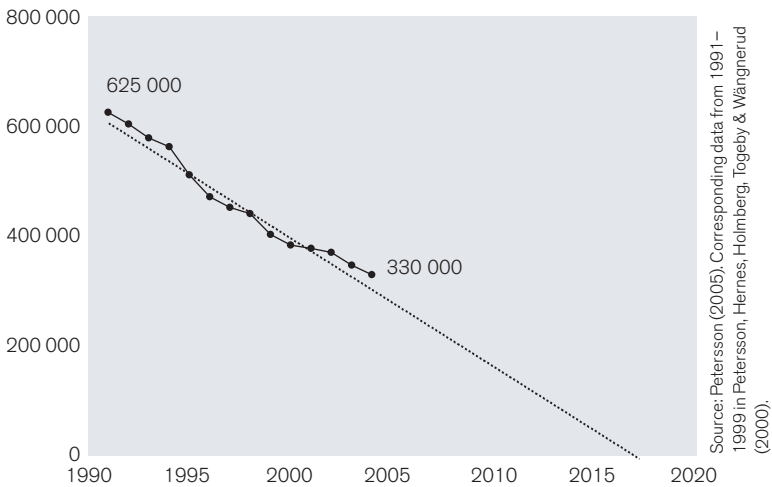

Figure 1.6 Membership in political parties 1991–2004

Total membership at each year's end in all the seven parties currently represented in the Riksdag. Official membership statistics from the respective parties. Some parties include members in affiliated organizations (such as women's associations). Youth organizations are not included.

The time series starts in 1991. Before that time, members of trade unions were collectively registered as members of the Social Democratic Party. For that reason, statistics before and after 1991 are not comparable.

The trend line is based on a linear regression of membership data from 1991 to 2004.

tem. The weakening of the parties' membership base has resulted in a communicative deficit between the rank-and-file and party elites. The weakening of parties' ability to generate opinion has left a vacuum that journalists and the media help to fill.

That fewer people are actively engaged in the work of the parties or are less attuned to party ideology means more leeway for the press, radio and television to exert political influence. In an era when most voters strongly identified with their party and voted for it faithfully in election after election the media's role was essentially to strengthen them in their con-

victions. Many people, too, chose their newspaper on the basis of its party color (Westerståhl & Janson 1958, Westerståhl 1964). When both the electorate and the media have broken their ties with the party system, we have a quite different situation. What the parties or the media choose to highlight on the election campaign agenda will influence the outcome to a much greater extent.

A triangle drama

Modern election campaigns in European democracies have three principal actors: citizens (voters), parties (politicians) and media (journalists). It is not entirely inaccurate to describe the interactions between the three as a triangle drama. The triad recurs in the current literature in a number of

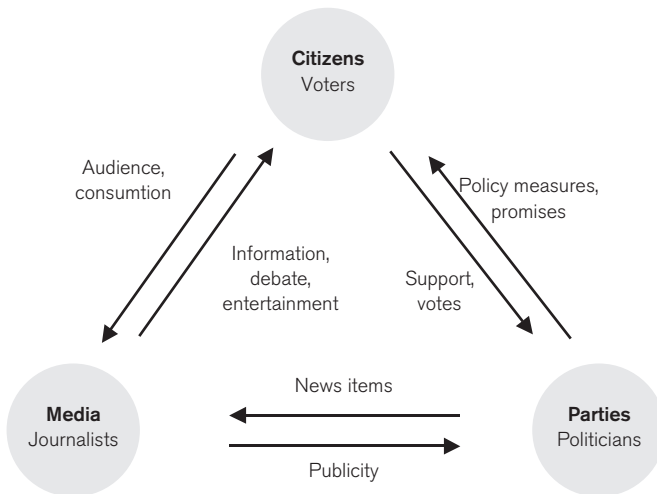

Figure 1.7 The election triangle

variants (Buchanan 2001, Brettschneider 2005). The power relationships between the three can be analyzed in terms of exchange relations (Hernes 1975). The mutual dependencies between them form a triangle (Figure 1.7):

Politicians are dependent on the support and votes of the citizenry. Citizens are, in turn, influenced by decisions and promises that politicians control. The media's influence depends on the extent to which politicians and citizens communicate indirectly. The media are dependent on readers/audiences and subscribers. Citizens, in turn, depend on the media for information, current debate and entertainment. There is a mutual dependency between the parties and the media, as well: politicians are news sources and can give journalists insights into ongoing processes; journalists control the fora that politicians need to make themselves and their views known.

Problems of integrity

The tensions in the triangle drama arise out of the necessity and legitimacy of all three parties. Problems or conflicts between the three cannot be solved at the expense of any one of them. On the contrary, a vital democracy requires that the media, parties and voters operate independently and with full freedom to play their respective roles.

A well-functioning democracy requires independent journalism having its base in media characterized by a high degree of integrity, both within the organization and vis-à-vis other institutions (Petersson, Djerf-Pierre, Strömbäck & Weibull 2005). The same argument applies to the roles of the media in election campaigns. Each medium must define its standards of integrity within the organization: What are the values, norms and rules that should guide our campaign coverage? And media must be able to defend their integrity in others' estimation: How to be able to stand up to the pressures,

ethically acceptable or otherwise, that inevitably occur in the heat of the contest?

Political parties, too, need to maintain their integrity. They run a dual risk of either being engulfed by the so-called logic of the media or becoming populist slaves of transient vogues in public opinion (Altheide & Snow 1979). In both cases the parties risk losing control of their agendas. The inner integrity of a political party is based on its ideology, but also on a responsibility for the democratic process and political culture. This latter responsibility is something that all parties share. Maintaining parties' external integrity requires constant awareness of the threats to it, not least the strategies of interest groups who seek to twist and steer campaign debates toward themes that serve their particular interests.

The citizenry, too, may be analyzed in terms of integrity, which implies that the act of voting has a qualitative as well as a quantitative aspect. General suffrage on the principle of »one man, one vote« means that all votes should be equal, that none is worth more than any other. But each vote is the outcome of a decision-making process, and that process can be more or less conscious, more or less deliberate. Ignorance and prejudice are human frailties, even in relation to elections. Voters characterized by high levels of integrity personify the ideal of the citizen in a democracy; they are self-reliant, knowledgeable and critical individuals. There is a reason why Swedish democracy, according to the Constitution, is »founded on the free formation of opinion«.

Thus, the election triangle may also be used as the basis for a normative theory of election campaigns. Ideally, elections in representative democracies require that media, parties and citizens all demonstrate a high degree of integrity.

Historical variation

The election triangle model is so generally formulated that it may be applied to many different situations and societies, but even the very cursory historical overview offered in the preceding pages indicates that it is not altogether universally applicable. In some instances voters and candidates have been able to communicate directly, with no need of media. The three concepts, media, parties and voters, have also been differently defined over time.

The metamorphoses of media, parties and voters means that we may hardly speak of a single, stable Swedish model of election campaigns. Originally, campaigns were personal, and candidates met their potential voters face-to-face. Personal contacts were reinforced by visits from campaign staff who canvassed neighborhoods and workplaces and urged people to vote for their candidate. Indirect forms of communication were an important complement even in early days, with leaflets and handbills being widely distributed. In the latter part of the nineteenth century the daily press emerged as an important platform. As newspapers were partisan, the parties could control their political coverage. In early years radio was only a complement, but the medium gradually became more important as a counterbalance to the partisan press; all parties had equal, if limited, access to the air waves. An important turning point came in the 1960s, when political journalists began to break their ties to the various parties – first in the broadcast media and then in the daily press.

Today, ever keener competition among the media for both audiences/readers and advertising revenue have forced media both to slim their organizations and to pay greater deference to commercial interests. Commercialization of the media threatens journalistic integrity (Petersson, Djerf-Pierre, Strömbäck & Weibull 2005).

International variation

International variation, too, lends itself to analysis according to the election triangle model. Media, politicians and voters play a central role in all modern democracies, but the constellations and power relationships differ.

Politicians in liberal media systems like that in the USA are especially dependent on mass media in order to reach the voters, for one thing because the parties are not deeply and widely rooted among the populace. The commercial interests of the media influence their relations with both politicians and the public.

The system described as polarized pluralism that is prevalent in countries like Italy displays quite different power relationships between politicians and the media. In these systems the power to legislate has been an important instrument for laying the ground rules for election campaigns. Politicians control the media through government regulation.

The democratic corporatist model of the kind practiced in countries like Sweden represent yet another variant of the relationships prevailing between the points of the triangle. Earlier, the parties exercised extensive control over opinion formation via their membership organizations and through affiliated print media. Power over opinion formation has successively shifted over to journalists employed by independent media, public service broadcasting included.

A focus on Swedish election campaigns

Thus, the relationships between media, parties and voters can vary widely, both over time and space. Now we shall turn to examine recent years' election campaigns in Sweden with an eye to spotting changes that are currently in progress. The material under analysis comes mainly from media and Elections Studies conducted in connection with recent elections to the Swedish Riksdag. In some cases the data have been

complemented with special studies of our own. As this book goes to press fully six months before Election Day 2006, this year's campaign is not included.

We have chosen to structure our discussion on the basis of the election triangle, treating our subject from the vantage point of each of its respective points: Chapter 2 focuses on media's treatment of election campaigns. Chapter 3 looks at campaigns from the point of view of the parties. Chapter 4 analyzes campaigns from the point of view of the voters. Thereafter, Chapter 5 speculates as to the nature of future election campaigns. Finally, Chapter 6 recapitulates the main conclusions of the analyses.

2. The Media's Campaign

»Arguments that focus on personal traits play virtually no role in Swedish election debates« (Westerståhl & Särilvik 1956:64).

In their pioneering study Jörgen Westerståhl and Bo Särilvik found that one of the premises of American election campaigns as documented in the research literature had little relevance to Swedish election campaigning. The political institutions and party organizations, the media structure and the political culture in the USA combined to give individual candidates a quite different status. Candidates' personal qualities played a focal role in election campaigns in the USA.

There was no lack of political 'personalities' in Sweden of the 1950s. On the contrary, party leaders received a lot of attention in news reports from political meetings and rallies and in editorial comment. Westerståhl and Särilvik found, for example, that op-ed writers tended to focus more on the faults of politicians in opposing parties than on the merits of their own. But media interest in individual politicians was generally confined to political aspects and only exceptionally were politicians' personality and character discussed, even less their private lives.

The overall picture in Swedish election campaigns of today is different. The logic of the media is said to have brought about an individualization and intimization of the public sphere, politics included. This process coincides with more general changes in voters' political behavior toward more volatile voters, weaker party identification, later voting deci-

sions and split votes in the simultaneous elections to national, regional and local assemblies.

More and more people come in contact with the political sphere via the media, which gives the media more power and influence. Furthermore, the media's hold on the political agenda grows stronger, as does their influence on public opinion, the greater people's need of orientation, which has to do with their uncertainty and how relevant they perceive news reporting to be (McCombs 2006).

The media may serve as arenas or as actors. As arenas the media offer politicians a means of communicating with voters. In this role the media are relatively passive and neutral: the agenda tends to be set by the most well-financed and creative political actors. When media are actors, journalists are more active in steering and interpreting the political debate with a more or less explicit ambition to set the agenda.

One example where Swedish media mainly serve as an arena is the traditional debates between party leaders televised at the end of the campaign. In these programs the party leaders speak, and traditionally journalists' role has largely been confined to that of referee. In the debates carried on TV4 journalists have been more active, and a tendency in that direction is noticeable on the public service channels (SVT), as well. An example of media as actors is the news analysis published in newspapers' news columns, where journalists explicitly and independently interpret political events and processes and express their opinions of current proposals and political developments. It is often difficult to decide which role the media are playing. The grey zones are many, particularly in news journalism.

What most of the channels that carry political information have in common is that they are fundamentally media-steered. The media decide what programs will be aired, who will be given the opportunity to speak, and what topics will be discussed. The media themselves decide whether they will

Rules and Regulations Pertaining to Election Campaigns

The degree of regulation of election campaigns varies widely between countries and different parts of the world. Countries like the USA, Australia, New Zealand and Canada have rules that regulate the party system per se, e.g., the nominating process and primary elections and some, albeit not particularly effective rules on campaign financing. But when it comes to media coverage of election campaigns there are essentially no formal rules or regulations. Paid political advertising in all conceivable forms is allowed.

At the other end of the scale we find the Japanese system. Japan has extensive rules concerning the kinds of campaign activities that are permitted, strict regulation of campaign financing, and detailed rules relating to political advertising in mass media and outdoor advertising.

Western Europe. The countries of Western Europe are mid-scale when it comes to regulation. The regulations consist of both restrictions and obligations, the latter far fewer than the former. One example of an obligatory requirement is the demand in many countries that television make air time available free of charge to the parties during election campaigns so as to give them an opportunity to speak directly to the voter. Such a requirement exists in Italy, for example, but not in Sweden.

Many European countries have laws that regulate campaign budgets, providing for transparency, capping contributions, and banning certain sources of funding. As for the media, some countries restrict the publication of the results of opinion polls during the campaign, and some restrict political advertising, especially on television.

Many countries, including most of the countries of Southern Europe, have moratoria on the publication of opinion polls as Election Day approaches. No such restrictions are imposed in Fenno-Scandinavia (or in the USA). Typical of Scandinavia and most of Northern Europe is extensive public subsidization of election campaigns, combined with voluntary commitments to maintain certain standards and self-regulation when it comes to campaign tactics and media strategies. Northern and Southern Europe differ markedly, not least with regard to the roles mass media play.

Italy. In Italy the media are circumscribed by numerous rules and regulations during election campaigns. Since 2000, there are special rules providing for equal treatment of the parties, 'Par Condicio'. The main objective is to ensure that all the parties have the same opportunities for media exposure during the campaign. The law, piloted through Parliament by a Center-Left coalition government, has the character of framework legislation. The details of the regulations have to be renegotiated in connection with each election. Par Condicio focuses primarily on television, commercial as well as public service channels, and on the last four weeks before Election Day. Other rules apply to campaigns up to that point. The law does not apply to political journalism at any other time.

The equal treatment law means, among other things, that no opinion poll results may be published the last 15 days of the campaign. This rule, and it

alone, applies to all media. All reports of polling results must include information on sample size, the exact formulation of the questions asked, and so forth. The polls are also to be 'audited' by a Communication Authority, which publishes them on its website.

The equal treatment law also prohibits paid political advertising on television, which has been established practice since the 1970s. Instead, the channels have to make free air time available to allow the parties to air programs of their own making (Mazzoleni, forthcoming). Parties must be treated equally in this regard, with the same number of presentations in equally attractive slots.

The law differentiates between informazione politico and comunicazione politico. The first refers to news and other programs produced by news departments. Such programs are required to observe strict balance during the last four weeks before Election Day. That is, if someone expresses an opinion, it has to be balanced by a contradictory view (provided opposing views exist), but not necessarily in the same program. Comunicazione politico refers to special election programs of an informational character: programs about the issues and different points of view. Here a complex of rules apply, the gist of which is that spokespersons for the parties shall be allotted air time in proportion to their parties' representation in Parliament. Thus, the law prescribes a strict standard of fairness in terms of space and attention. It does not, however, take account of other forms of favoritism, such as bias and tactical selection of issues. Finally, the law prohibits the appearance of politicians in entertainment programs the last month before the election.

Sweden. Rather few regulations surround political journalism in Sweden. In the case of the daily press there are no formal requirements other than those stipulated in the Freedom of the Press Act, which covers more general issues such as libel and threats to or disparagement of minorities. In broadcasting, the public service channels and TV4, whose charters require them to produce news and public affairs programming, are regulated under the Radio and Television Act. The three television channels should maintain an impartial stance and may not carry political advertising. Nor may commercial channels whose signals originate from countries that do not allow political advertisements. The latter provision applies to Swedish TV3 and TV5, which distribute their signals via satellite from Great Britain. The charters for newer analogue and digital niche channels allow political advertisements, however.

The obligation to carry news and public affairs programming imposed on public service radio and television (SR and SVT) is demanding of resources, but regulation is not detailed. The charters for the two companies state that they »shall present news, stimulate debate, comment on events and processes and provide citizens with the all-round information they need to be well-oriented and to be able to form opinions on social and cultural issues«. How they should go about doing this is left to the companies' judgment. By and large, political journalism, like so many other aspects of media content, is regulated on the principle of 'freedom under responsibility', i.e., through self-regulation and voluntary agreements between the media and those having a stake in the election.

be mainly arenas or actors. In the case of the press there are no formal rules other than the constitutional law on Freedom of the Press, whereas broadcast media are regulated by the Law on Radio and Television and by the terms of their concessions. None of these documents set out rules for election coverage; instead, the system relies on self-governance, voluntary negotiations and agreements between the different participants in the campaign. In 2002, for example, the public service broadcaster, Sveriges Television (SVT) invited the parties to discuss what issues the final party leader debate would cover (Nord & Strömbäck 2003), but SVT had the final say.

All in all, Sweden differs from many other countries in that the system neither gives political parties free air time or – so far, at least – the possibility to purchase television and radio spots. A recent survey of 28 democracies around the world (Holtz-Bacha & Kaid 2006) found that political advertising (paid air time) was allowed in 19 of them. In some of these nineteen countries advertising was allowed on public service channels, as well. Twenty of the countries surveyed had provisions for free air time, the content of which the political parties themselves controlled.

The details vary, but common to most of the countries – Finland, the USA and Germany among them – is that television provides air time, paid or unpaid, for party-steered political information. The Swedish system offers no such opportunities. Sweden has no ‘party election broadcasts’ as in Great Britain, where the parties are allotted free air time in which to transmit programs of their own making (Franklin 2004, McNair 2000).

Election campaigns today are not only mediated, but they are largely media-steered or ‘medialized’. That is, they are imbued with and tailored according to the objectives media set for political journalism and election coverage. The campaigns have to be responsive to ‘the logic of the media’, the rationale according to which media make their choices re-

garding news value, presentation, forms of address, rhythm, tempo and topic (Asp 1986, Strömbäck 2004, Gulati, Just & Crigler 2004, Meyer 2002).

The media's influence over content and their importance as citizens' source of information give them a great deal of power both before, during and after the campaign. When most powerful, they can choose what to report about (the power of selection), how to report it (the power of interpretation) and at times when people are most receptive to media influence through their exposure to the media and their need of orientation (cf. Asp 1986, McCombs 2006, Strömbäck 2004). This power applies to all journalism and thus to election coverage of all kinds.

Elections to the Riksdag: Good news

Parliamentary elections are important to the parties, but they are also important to Swedish media. Heightened public interest in politics in election years means greater interest in news journalism overall, and especially articles, programs and news stories relating to the election. Election campaigns are often dramatic and exciting, which makes 'good copy'. They provide an opportunity for innovation: new kinds of programs, new angles. Election years also give the media ample opportunity to demonstrate their vital role in the democratic process.

As a consequence, Swedish media devote a good deal of energy and resources to covering politics and election campaigns. Studies of political reporting overall have found no indications whatsoever of a tendency to downplay political news or to reduce the volume of political coverage. The share of domestic news among the totality of news items may vary, but in recent decades the proportions have been relatively stable (Figure 2.1). This forms a contrast to the situa-

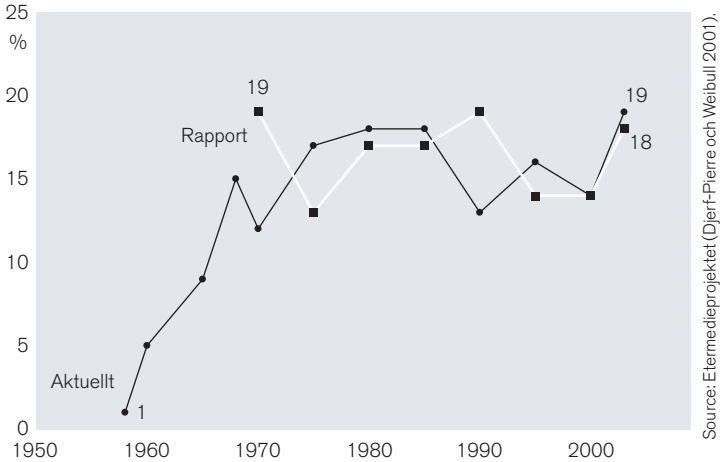

Figure 2.1 Domestic politics on Swedish public service television (SVT)

Percentages of items aired. The analysis includes all news items in the public service

television main newscasts eight weeks (1958–2000) and four weeks (2002–2003) a year.

tion in the USA, where since the mid-1970s the media have cut back on the volume of domestic news coverage – until the terror attacks of 2001 broke the trend (Farnsworth & Lichter 2006, Graber 2006).

In election years Swedish media redouble their political coverage. In the campaign of 2002, public service television offered 35 hours of election programming on the two SVT analogue channels and considerably more on its digital ‘round-the-clock news channel, SVT24. This is considerably more than a couple of decades ago (Figure 2.2).

The increase in transmission time devoted to election programming is an indicator of the priority accorded election coverage, but it also reflects the expansion of the Swedish media sector, particularly over the past decade. Examples of special programming in the campaign of 2002 were an elec-

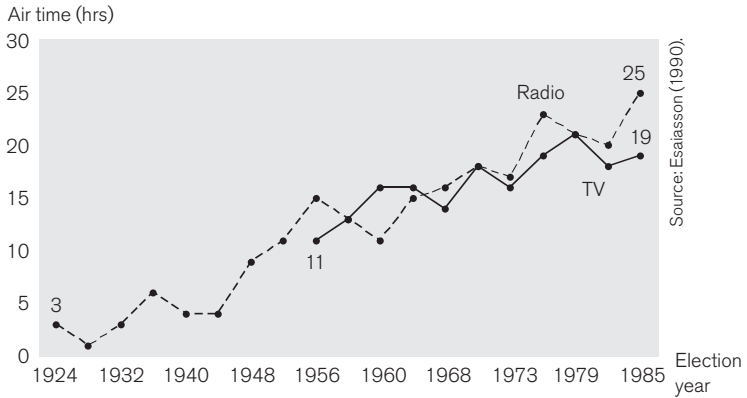

Figure 2.2 Election programs on radio and television 1924–1985

The material does not include newscasts. Calculation based on press reports.

tion duel between Prime Minister Göran Persson and the Conservative Party leader at that time, Bo Lundgren on SVT. Both SVT and TV4 also carried interviews with all the party leaders and a final debate. Public service radio, too, carried interviews with the party leaders among a number of other election-related programs. In addition, there are a number of regularly scheduled programs of public affairs and news commentary that focus on elections, in whole or in part, during campaigns. In 2002, *Uppdrag Granskning*, a weekly program of investigative journalism on SVT, aroused considerable debate when reporters surreptitiously recorded what campaign workers were saying about immigration and immigrants to voters who visited their campaign stalls (Andén-Papadopoulos 2003, Johansson 2006).

News coverage of the elections, too, is fairly extensive, albeit hardly on the scale of coverage given major catastrophes like the tsunami in the Indian Ocean in 2004 (Andersson

Odén, Ghersetti & Wallin 2005). In the last three weeks before Election Day 2002, Swedish media – Expressen, Aftonbladet, Dagens Nyheter, Svenska Dagbladet, TV4 Nyheterna 18.30, Rapport 19.30 (SVT1) and Aktuellt 21.00 (SVT2) – carried more than 1,100 items having to do with the election. This represented a slight increase over the preceding election in 1998. Broadcast media aired about ten hours of election programming, while newspapers published about four column-kilometers (2.5 column miles), photos, graphics and illustrations included (Strömbäck 2004). In addition, there is news coverage on regional channels and stations and election material published on media websites.

In short, we may say there was no lack of election information in Swedish mass media in 2002. But that elections to the Riksdag are considered important does not mean that all elections have intrinsic news-value. This is particularly clear in the case of elections to the European Parliament, where coverage is considerably less extensive and is primarily concentrated to the last week of the campaign (Nord & Strömbäck 2006). Coverage of the European Parliament election of 2004 amounted to about one-third of the general election coverage of 2002 (Abramsson & Strömbäck 2004, Strömbäck & Nord, forthcoming).

Of course, this is not true of all media. The commercial television channels that were introduced in the 1980s and 1990s do not devote much attention to politics – or to news at all, for that matter. All in all, politics is largely left to the traditional media.

The surge of material on offer has resulted in an imbalance between supply and demand. The media have to compete for readers' and audiences' attention. Within each medium there is also an internal contest for time/space, money and staff between those working with election coverage and other departments and editorial desks (cf. Semetko, Blumler, Gurevitch & Weaver 1991).

Information and appeal

As part of their service to democracy the media are to inform citizens, scrutinize those in power, and make it possible for people to form their own opinions on issues, and on the various parties and their platforms (cf. *SOU 1995:37*, Meyer 2002, Norris 2000).

Judgments as to what kind of information is most important will depend on one's preferred model of democracy (Strömbäck 2004, 2005), but all models emphasize the vital importance of the information function, particularly when it includes calling those in power to account and opportunities for public discussion. Meanwhile, from the media's point of view, it is important for election coverage to be interesting and to appeal to readers, viewers and listeners, both of which qualities are necessary in the competition for public attention. Thus, election journalism may be said to have two overall tasks: to inform and to arouse interest. It shall have utilitarian value and appeal and have something to offer both those who are very interested in politics and those whose interest is no more than lukewarm (Ohlsson 1989, Johansson 2006). Information and appeal may be seen as two dimensions that, considered together, form four possible combinations (Figure 2.3).

		Informative?	
		No	Yes
Engaging?	No	I Meaningless election coverage	II Fact-filled election coverage
	Yes	III Dramatized election coverage	IV Good election coverage

Source: Johansson (2006).

Figure 2.3 Dimensions of election information

The ideal, of course, is that election journalism should be both highly informative and highly appealing. The ideal election coverage offers the information that people need to form an opinion in ways that arouse interest and inspire enthusiasm. The worst case is election coverage that is neither informative nor interesting. Such content may offer irrelevant or misleading information in a plain and boring fashion. It fully lives up to the characterization, »meaningless«.

Striking an optimal balance between information and appeal is not easy; it requires a good sense of priorities. If the journalist assigns too much priority to information, his or her coverage risks becoming overladen and unattractive. When media choose to broaden the appeal of their coverage by reducing the amount of information and emphasizing excitement and entertainment values, the result is a dramatization of the events (Johansson 2006).

Whereas the information value of articles, programs and news items may be determined by applying objective criteria, entertainment values are a function of personal tastes and preferences. Content that one person finds attractive and inspiring may well be dull and unappealing to another. Thus, a medium's choice of target audience, and how the staff conceive of that audience, decide the form and content of election coverage.

Strivings to combine information and appeal may lead to the development of new genres and changes in established ones. The term »infotainment« has been coined to describe material where informative elements are embedded in entertainment and, conversely, entertaining elements are introduced into essentially informative material. The old boundaries between information and entertainment have become fluid, in traditional media, as well.

Election programs on radio and television

Sweden has one of the longest traditions of televised debates among party leaders. As noted earlier, special election programming has been offered on public service radio and television since 1932. Few programs attract more viewers and listeners than the party leader debates (Gilljam & Holmberg 1995). A lot has changed these past few decades, however. For one thing, journalists' influence over the form and content of programming has increased, motivated by the desire to produce »good radio« and »good television«. In practice, this has meant programs with faster tempo, more surprises, spontaneity and drama.

The more attuned to ratings broadcasters have become, whether because of their dependence on advertising revenue (TV4) or issues of legitimacy (SVT), or simply as a measure of success, the more they are concerned about »reaching a lot of people« rather than how relevant or important what they have to say to those people might be. Programs are assigned ratings goals, i.e., audience sizes to be achieved, relative to specific, demographically defined audience segments. For example, the interviews of party leaders in the 2002 campaign on SVT were challenged to reach 8 per cent of those eligible to vote. Keener competition has made programs' ability to get through to viewers more important. Voter-steered interviews in the most recent elections are one example of the ways producers have sought to popularize programs, bond with viewers, and involve them in the program content.

An increase in journalists' influence over the interviews with party leaders is linked with a different conversational tone and a more querulous journalistic attitude. These changes are not motivated by any tendency on the part of party leaders to prevaricate or to dodge sensitive issues any more than party leaders have done in the past. Indeed, recent research has found that party leaders answer 80 per cent of the questions asked, and that 83 per cent of their responses are relevant (Esaiasson & Håkansson 2002).

The change in tone is also evident in how party leaders are addressed, interviewers' and interviewees' attire, and a lighter atmosphere with elements of humor, satire and entertainment. In the 1970s the trend toward informality and a lack of respect for authority coincided with a shift in journalistic ideals toward critical scrutiny.

Greater influence on the part of journalists over the interrogation of party leaders has hastened the tempo. The average number of changes of speaker per hour rose from 150 in the period 1956–1960 to 326 in the period 1976–1994. The number of question-and-answer interchanges per hour nearly doubled during the same interval, from 57 to 110. The party leaders have had to learn to talk faster. In the period 1956–1960 on average a party leader uttered 146 words per minute; in 1976–1994, the tempo had hastened to an average 184 words per minute. That the increase in tempo does not simply reflect the spirit of the times is indicated by the fact that the speed of speech in the party leader debates, where candidates have more control, remains the same as ever.

An indicator of the extent to which power over the agenda shifted from politicians to journalists is the frequency of interrupted speech in the party leader interviews from the elections of 1956 to 1998 (Esaïasson & Håkansson 2002). In the 1960s, party leaders were free to speak their minds without interruption. In the 1970s, interviewers began to take the initiative through counter- and follow-up questions. In the late 1990s, journalists interrupted the party leader one or more times in nearly half the interviews (Figure 2.4).

The content of the party leader interviews has also changed. In the period when journalists have taken more initiative we note a slight tendency toward less polemics. Party leaders are also less inclined to blame social problems on others. At the same time, there is seldom time to discuss the roots of social ills (Esaïasson & Håkansson 2002).

The party leader interviews show no tendency toward superficiality or over-simplification in the argumentation,

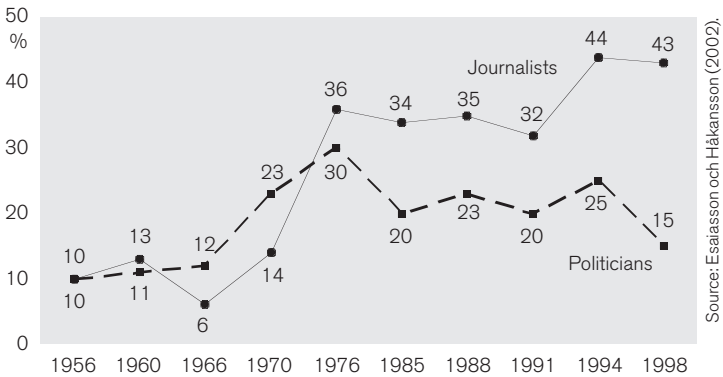

Figure 2.4 Who interrupts? Interviews with party leaders 1956–1998.

however. The party leaders are more inclined to propose concrete solutions and to state their positions on various issues, but the number of logical steps in their argumentation remains the same. Ideological perspectives are relatively rare, then as now. The campaign debate and party leader interviews mostly revolve around current political issues. A bit more than 10 per cent of the interrogations are about politics as a contest or game, as opposed to 7 per cent of the debates. Little has changed regarding the time perspective: since 1960, 70–80 per cent of the journalists' questions and about 60 per cent of the politicians' responses have been future-oriented rather than retrospective.

Summing up: The influence of the media and journalists in interviews with party leaders and campaign debates has increased as regards planning, execution and content. This has influenced the number of issues brought up, the conversational tone and the tempo. A desire to produce programs that catch viewers' and listeners' attention and that have a strong appeal imbues the programs. It is reflected in the higher tem-

po, a more 'popularized' and critical tone, and a reliance on humorous and entertaining elements.

There is an manifest tension between information value and strong appeal. SVT's planning documents relating to campaign coverage in 2002 refer to other objectives than pure information. Key words in channel management's terms of reference for the producers of the series, Valbar [an election 'salon'] were, for example, »interest, entertain, casual, unpretentious«. Corresponding terms for the series, Fläsk [The Pork Barrel] were »involve, provoke, entertain, tease«, for Ditt val [Your Choice], a program targeting youth, young adults and parents of young children, »conversational, young perspectives, alternatives, respect«, and for Karavanen [The Caravan, a series having a 'road-show' format], »offer meetings/make contact, mirror, humor«. Only in the case of the party leader interviews, the party leader duels and the final debate do we find traditional terms referring to the democratic functions of the medium. Here the key words were »mirror, inform« and, in the case of the interviews »scrutinize«. Election Night coverage was also described in terms of »mirror« and »inform«, together with »humor« and »suspense«.

The company's follow-up of its 2002 election coverage includes suggested improvements for coming years' coverage, stressing the importance of stronger appeal through more excitement and unexpected happenings. In the case of Duellen, a series of party leader duels, the evaluation recommends »an injection of something new and different into the normal routine that arouses [viewers'] interest«, and in the case of the final debate, »introducing some kind of surprise effect«.

Thus, the duties to mirror, inform and scrutinize are still foremost in SVT's thinking, but it is equally important to do so in an interesting, entertaining or provocative way. Election Night coverage should be highly informative, but the program's appeal should be given more emphasis in election years to come. This is SVT's view on election coverage in a nutshell.

News journalism during the campaign

Alongside the special election-related programs on radio and television, regular news journalism – political journalism between elections, news reporting during the long campaign from January to September of election years, and the intensive coverage of the final weeks leading up to Election Day – also plays a central role. According to content analyses performed by the media analysis company, Observer, the Social Democrats are the party that figures most frequently in lead stories in the press, radio and television (Table 2.1).

In the election outcome in 2002, three parties may be said to be over-represented in domestic news coverage: the Social

Table 2.1 The parties in lead stories 2002–2005.

Party	Bias news media 2002–2005	Coverage news media 2002–2005	Election results 2002	Difference: media coverage – election result
Left	– 20	10,1	8,4	+ 1,7
Social Democrats	– 24	43,7	39,9	+ 3,8
Greens	– 8	8,9	4,6	+ 4,3
Center	– 7	6,3	6,2	+ 0,1
Liberal	– 5	9,4	13,4	– 4,0
Christian Democrats	– 10	7,0	9,1	– 2,1
Moderate	– 5	12,1	15,3	– 3,2
Other	+ 14	2,5	3,1	– 0,6
Total		100,0	100,0	
N	13 607			

Period studied: from October 2002 to December 2005. The material analyzed consists of lead political stories in eight news media (Dagens Nyheter, Svenska Dagbladet, Expressen, Aftonbladet, Dagens Eko 16.45 (public service radio), Nyheterna 19.00, Rapport 19.30 samt Aktuellt 21.00, weekend 18.00.) The unit of analysis is the article/news item. Items can be counted more than once if more than one party is mentioned. Bias has been coded in terms of favorable, neutral or unfavorable of the respective parties.

Source media: Observer. The raw material was collected and analyzed by Observer Sverige AB. The database was made available to the authors of this report,

Democrats, the Left, and the Greens. That the ruling party should receive relatively extensive coverage is to be expected, and the same may be said of its political allies.

The Observer analysis also examines the extent to which the news has a positive (approving), neutral, or negative (critical) tendency. In the table these findings are summarized in a balance index, where scores, theoretically speaking, may vary between -100 (all news items are negative) and $+100$ (all items are positive). On the whole, coverage of the political parties shows a slightly negative tendency; only the new entries receive more favorable treatment.

Two parties, the Social Democrats and the Left Party, received decidedly critical treatment in news coverage during the period since the election of 2002 to the end of 2005. Both received relatively much media attention, but it was often of a negative character.

Elections are decided during the election campaign, but the campaigns and their dynamics are dependent on the events and processes that precede them. This was illustrated by the success of the Liberal Party in 2002, where the crucial issue was the party's proposal of a language test as a qualification for naturalized citizenship. That this issue received widespread coverage had a lot to do with the party's previous positioning as champions of a generous immigration and asylum policy. The proposal's news value consisted of what was perceived to be a deviation from the party's previous stance.

Media researcher Kent Asp's analyses of media coverage of the election campaigns between 1979 and 2002 show that the media always 'mistreat' some party or parties and favor others (Asp 2003) – but not systematically. The media's roles as friends or foes of the parties vary from campaign to campaign. Control over the agenda has also shifted between elections as a result of an interplay between voters, politicians and journalists.

Politicians have exerted a strong influence on the agenda in some campaigns. In others, »reality« – the prevailing social and economic situation in Sweden – has framed both politicians' messages and journalists' questions. Voters had considerable influence in the campaign of 1998, which largely revolved around issues of importance to people's everyday lives: health care, the schools, and social services. According to Asp, the election campaign of 2002 was more imbued with the logic of the media than any before. Thanks to the controversy surrounding the above-mentioned undercover recordings from election stalls and the Liberals' proposal of language tests as a criterion for Swedish citizenship, the integration issue dominated the campaign, although it had been assigned low priority by the parties and voters alike earlier in the year (Asp 2003).

The last month of a campaign can be decisive for the parties' success or failure. Still, one cannot generalize too far inasmuch as each campaign has its own special dynamics. The media play a dual role as both arenas and actors. Media researchers say that the power of the media resides in their ability to set the agenda, but research also shows that the media can and do influence how people perceive and understand news content through processes of priming and framing (Iyengar 1991, McCombs 2006, Reese, Gandy & Grant 2001, McCombs, Shaw & Weaver 1997). The media can influence not only which issues people consider important, but people's reality perceptions and their patterns of association, as well (Iyengar & Kinder 1987).

Given this potential, it is hardly surprising that the image of the parties given in the media has been closely related to the success or failure of the parties in every election since 1979. It would appear, however, that most important is not whether the attention has been predominantly positive or negative, but how frequently the parties are mentioned by others or appear as actors. This is illustrated in a comparison

Table 2.2 Media coverage and election results 2002.

Party	Media coverage during the election campaign	Election results	Difference
Left	7	8,4	- 1,4
Social Democrats	34	39,9	- 5,9
Greens	8	4,6	+ 3,4
Center	7	6,2	+ 0,8
Liberal	14	13,4	+ 0,6
Christian Democrats	9	9,1	- 0,1
Moderate	17	15,3	+ 1,7
Other	4	3,1	+ 0,9
Total	100	100	

Media coverage refers to how often the parties appeared or were mentioned as actors in Ekot (public service radio news), Rapport and Aktuellt (news programs in public service TV), TV4 Nyheterna, and daily newspapers Svenska Dagbladet, Dagens Nyheter, Göteborgs-Posten, Aftonbladet and Expressen during the last four weeks of the election campaign.

Source media coverage: Asp (2003).

of the party's media exposure during the last four weeks before Election Day in 2002 with the outcome of the election (Table 2.2, Asp 2003)

Partisan bias in campaign coverage

Of all the issues relating to the practice of news journalism, few arouse as much debate as suspicions of partisan bias. Every now and then politicians on the Left complain of conservative bias in the press on the basis of the fact that most media are privately owned, and most newspapers express Liberal or more generally non-socialist sympathies in their opinion columns. Corresponding complaints of Leftist bias in the media are heard from the Right; these suspicions are based on the fact that preferences for the Left Party and the Greens

are more common among journalists than among the population at large (Asp 2001).

Similar discussions along roughly the same lines take place in many countries of the democratic corporative or liberal model, not least in the USA, where the issue of »liberal bias« is ever-present (cf. Farnsworth & Lichter 2006, Graber 2006, Patterson 1993). In countries characterized by polarized pluralism, e.g., Italy, the issue is less salient inasmuch as the media are more closely integrated into the political system. There, partisanship on the part of any medium is only natural, not a deviation from a norm of impartiality.

Kent Asp has examined the performance of Swedish media in election campaigns since 1979 with respect to their neutrality or partisan bias (Asp 2003). His analyses take their starting point in two forms of mention: parties as objects (of others' comments) and as active subjects. The raw data are summarized in an 'actor treatment index', constructed on the basis of the extent to which the parties receive media attention and the extent to which mention is positive/approving or negative/critical. Parties that are much criticized are considered to receive unfavorable treatment, irrespective of the source of the criticism (other parties, journalists, etc.), whereas parties that are frequently mentioned and in positive terms are considered to receive favorable treatment.

Asp finds that in every election campaign one or more parties receive favorable treatment, while one or more others are treated unfavorably, but that the constellations differ from campaign to campaign. In this sense, there is no evidence of partisanship, neither Left nor Right, in the Swedish media. Instead, media might be characterized as unpredictable. In the election of 2002 the Liberal Party was most favored, but the party was among those receiving unfavorable treatment in 1998.

The main conclusion is that Swedish media do not systematically favor or disfavor any party, but there are certain ex-

ceptions. The Conservatives and the Social Democrats consistently receive less favorable treatment than other parties from the public service broadcasters, SR and SVT. This need not indicate partisanship, however. It may be due to the fact that these two parties are the two largest and also the main protagonists in the contest for power. They may therefore draw more fire than other parties. In other words, the 'unfavorable treatment' may originate among the parties rather than among journalists.

Most Swedish political journalism is neither positive nor negative, but neutral. The frequency of negative news varies over time, albeit some parties are more frequently the object

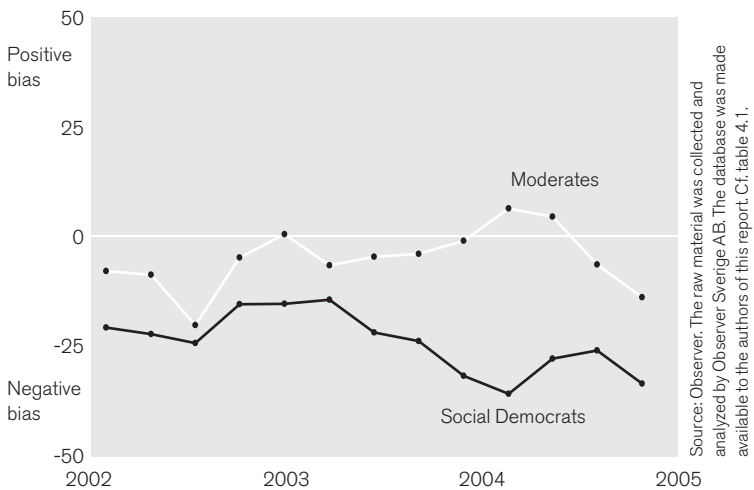

Figure 2.5 News media bias: the two major political parties 2002–2005

Period studied: from October 2002 to December 2005. The material analyzed consists of lead political stories in eight news media (*Dagens Nyheter*, *Svenska Dagbladet*, *Expressen*, *Aftonbladet*, *Dagens Eko* 16.45 (public service radio), *Nyheterna* 19.00, *Rapport* 19.30

samt *Aktuellt* 21.00, weekend 18.00.) The unit of analysis is the article/news item. Items can be counted more than once if more than one party is mentioned. Bias has been coded in terms of favorable, neutral or unfavorable of the respective parties.

of media bias than others. A secondary analysis of Observer's empirical data shows significant fluctuations for both the Social Democrats and the Conservatives in the period between election campaigns (Figure 2.5).

Whether a party receives approving or critical treatment varies from month to month. Even quarterly differences are sizeable. During the entire period from the election of 2002 through 2005, Social Democrats received less favorable treatment than the Conservative Party. The difference was especially great at the end of 2004 and in early 2005.

As for treatment of the two main political blocs, socialist and non-socialist, during election campaigns, a study of the period since 1979 found that the non-socialist bloc has tended to receive more favorable treatment on the whole, but that the tendency varies among the media. Overall, the non-so-

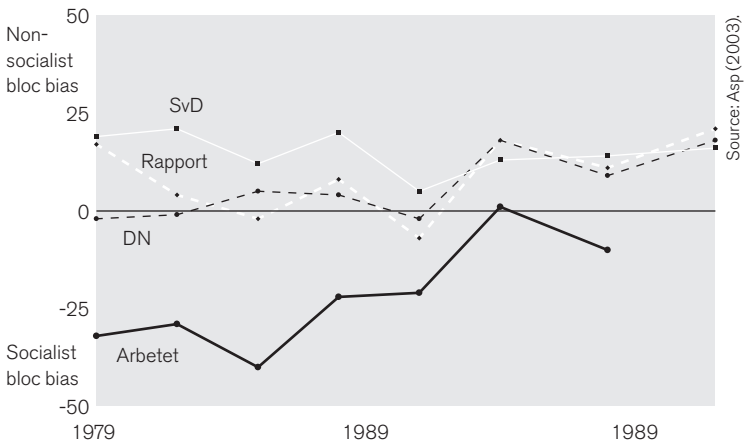

Figure 2.6 Media bias in reports about political parties 1979–2002

Actor treatment index: relationship between exposure and bias the two major political blocs. The material analyzed is election coverage since

1979 in *Rapport* (public service TV), and the newspapers, *Arbetet* (through 1998), *Dagens Nyheter* and *Svenska Dagbladet*.

cialist bloc has been favored most by Svenska Dagbladet, a Stockholm morning paper that describes itself as »independently Conservative«, while the Social Democrats have been favored by papers like Aftonbladet, a nationally distributed tabloid that is affiliated with the labor movement.

The findings suggest that the Swedish press has become more balanced in terms of party partisanship. Treatment of the two blocs has varied between elections, however. Interestingly, the media tend to flock together as regards changes in treatment of the blocs between elections (Figure 2.6). The media have changed in like manner in 26 of 30 possible cases (Asp 2003).

In other words, as a rule there is a large measure of consensus in the media's estimation of the party blocs, irrespective of journalists' personal sympathies, the party hue of newspapers' op-ed columns, or owners' interests. Whether a party is favored or disfavored is more a function of journalistic values than of partisanship. Thus, the question of a tendency in the media is not a matter of partisan bias, it is more a question of bias in favor of the media logic, i.e., of so-called 'medialization' (Asp 1996).

Medialized election coverage

The term »medialization« refers to a situation where journalists' professional norms, routines and news values steer the media's reporting (Hernes 1978, Asp 1986). A corresponding term in the anglophone literature is »structural bias« (Gulati, Just & Crigler 2004, Graber 2006). The factors behind medialization include the media's need to compete for readers' and audiences' attention, prevailing news values, the media's format and the resources at editorial desks' disposal.

Although the practice of journalism differs between countries with different traditions regarding the interplay of poli-

tics and media, the journalism produced by commercial media is as a rule more oriented toward readers, viewers and listeners with a view to catching the attention and interest of the medium's target audience. The more volatile the demographic group and the less interested in politics they are perceived to be, the greater the likelihood that the journalistic product will be given a popularizing twist in an effort to reach its readers, etc.

Journalistic narration is based on a number of dramaturgical assessments (Ghersetti 2004). The more dramatically a story can be told, the better the story from a journalistic point of view. As in all narration, there needs to be a clear story-line or leitmotif that can be both inclusive and exclusive. Perspectives, events and people that 'fit' the established narrative are played up, whereas those that complicate or muddle the story tend to be toned down or suppressed.

In order to arouse attention and interest, the media tend to describe politics as a contest or game, reduce complexity and focus on events and people rather than abstract principle and rationales/trains of thought. Common techniques are personification, popularization and polarization (Hernes 1978, Asp 1986, Petersson & Carlberg 1990, Strömbäck 2000).

Personification: The party leader as symbol

A stirring example of personification is the transformation of the Liberal Party leader, Lars Leijonborg, from »something out of Mme Tussaud's« to »The Lion King« in the campaign of 2002 (Persson & Tellström 2003, Strömbäck 2004). The events of that campaign show how medialization either deliberately, or, as is often the case, as a collateral side-effect can cast a politician or issue in a favorable light.

In early August, the 2002 election campaign looked like it would be one of the duller in Swedish history. The polls predicted that the Social Democrats would stay in power, and it

appeared that the issues would be the same as those in 1998: health care, the schools, and social services. Viewed from a journalistic perspective, the campaign promised no surprises or excitement, in short, nothing that would be fun to cover and that could be counted on to interest readers, viewers and listeners. There was no »news« – as defined by professional criteria – in sight. It was at this point that the Liberal Party put forth its proposal of mandatory language tests for immigrants seeking Swedish citizenship. The proposal came unexpectedly and formed a contrast with the party's previously generous position on immigration. What is more, it provoked forceful criticism from the Social Democrats and others, the conflict rendering the proposal even more 'newsworthy'. When a few days later the polls showed a slight upturn for the Liberals, the media were quick to follow it up.

Even then, six weeks before Election Day, the media began casting Leijonborg in the role of »The Lion King«, parallel with a theme of Conservative Party leader Bo Lundgren as the election's loser. Heightened media attention led to better numbers in the polls, which in turn led to even more media attention and even higher figures. Lars Leijonborg, who only weeks earlier had been portrayed as a loser, emerged as »The Lion King« and a winner. Thus, the media can help to fulfill their own prophecies. Significant in this context is the fact that, despite his party's success in the election, Leijonborg was found to be less popular than several other party leaders in the SOM Institute's Election Study of 2002 (Holmberg & Oscarsson 2004).

Personification in the form of a focus on party leaders as active subjects has increased compared to earlier years, particularly in the final days of the election campaign (Johansson 2006). Thus, personification in Swedish political news journalism has increased, but it would be hasty to conclude that Swedish voters, too, have become more oriented toward politicians as individuals. Party leaders' impact on voting is gen-

erally slight, and the relatively recently introduced option of selecting individual candidates has not led to greater popular awareness, let alone familiarity with the individual members of the Riksdag. In sum, the party leader may symbolize the party, but voters vote primarily on the basis of ideology and the issues (Holmberg & Oscarsson 2004).

Popularization: politics as game and drama

Journalistic narratives use specific techniques for framing and depicting what the news is about. An awareness of these frames helps us understand both the content of journalism and its effects. Theories of framing and agenda-setting help to explain the power of the media.

One principal theme that journalists often use, particularly in the period leading up to an election, is to describe politics as a game of strategy (Patterson 1993, Cappella & Jamieson 1997, Strömbäck 2004, Waldahl & Narud 2004). Here the focus rests on winners and losers in the contest for voters, on campaign strategies, on political style and on power relationships and/or personal relationships between political actors. Politics tends to be reduced to a contest for power, where power is treated as an end in itself rather than a prerequisite to enacting policy. Political issues and ideas are depicted rather as a ways to win votes and to attain a position of power.

When the focus rests on the substance of politics – on policy and solutions to real problems – journalism consists of reporting what has happened, what different figures have proposed, and comments and reactions relating to the issues from different quarters. The contest for votes and political power is either absent, toned down or described as a means to an end, viz., being able to enact certain policies. Meanwhile, personification and framing are linked, inasmuch as the central actors, »players« in the game are generally indi-

vidual politicians, usually party leaders, rather than the parties as collectives.

The boundaries between politics-as-game and the substance of politics are not always distinct. There is, for example, a difference between news items that report the results of an opinion poll and items about which parties are likely to form a coalition government and what each of the parties will bargain for. In both cases politics is seen as a game or contest, but in the latter case there is a direct link to the issues and concrete policies.

How common the resort to framing politics as a game is varies between media, between elections and campaigns, and between different inter-election periods. In connection with the elections of 1998 and 2002, politics was depicted in terms of its substance, the issues, in 45 and 55 per cent of all news items, respectively; the game approach was used in 38 and 35 per cent. The news media that most tended to frame politics as a game in the 2002 campaign were *Expressen* (nationally distributed tabloid) and commercial TV4 *Nyheterna*, whereas the public service newscasts, *Rapport* (SVT1), *Aktuellt* (SVT2) and *Dagens Nyheter* (nationally distributed morning paper) primarily discussed politics in terms of the issues (Strömbäck 2004).

Framing politics as a strategic contest can make election coverage more exciting. Whereas the political issues remain more or less the same during the campaign, the parties' campaigns and their contest for votes constitute an ever turning and twisting drama – intrinsically exciting, and thus easy to write about in an engaging manner. As Election Day nears, television news tend to emphasize game aspects rather than the issues (Figure 2.7). Swedish television newscasts devote about as much attention to the issues today as they did twenty years ago, however.

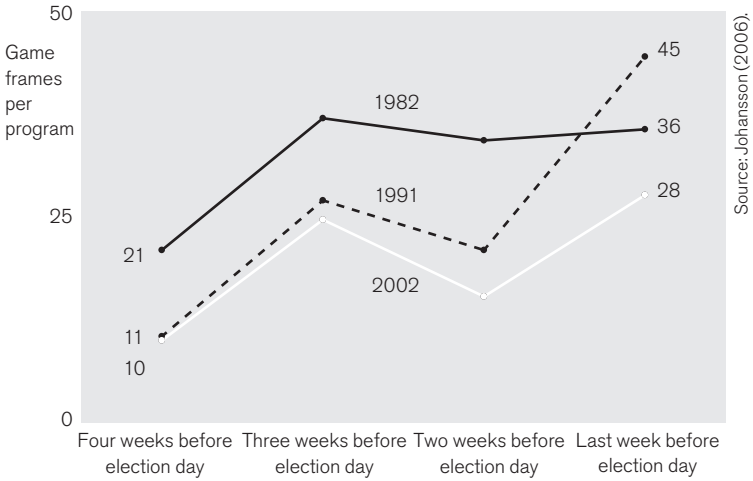

Figure 2.7 Game frames in television election coverage.

Game frames in television election coverage 1982, 1991 and 2002 the final four weeks

before election day. Proportion of instances of game framing per news program.

Polarization: conflict and mistrust

Framing party politics in terms of conflict and contest is an established technique of medialization. This is not to say that contemporary media are any more conflict-oriented than media decades ago. The level of conflict in media coverage does not appear to have changed. The frequency of critical/skeptical comments in television campaign coverage was about the same in 2002 as in 1982 (Johansson 2006). Newspapers' coverage is no different. The focus on issues is as strong as ever, heated exchanges and verbal battles are no more frequent, but rather the contrary. Nor has the share of articles in which politics is framed as a contest or power struggle increased (Ekström & Andersson 1999).

Election coverage has changed in other respects, however. Expressions of mistrust or skepticism have become signif-

icantly more common in television news. The frequency of items in newscasts where »mistrust of politicians« is a notable feature (two weeks before Election Day) increased from 14 per cent in 1979 to 31 per cent in 1998 (Ekström & Andersson 1999). Politicians were characterized as untrustworthy in one-fourth of the articles and items in the final three weeks of the campaign of 1998 (Strömbäck 2001). In addition, there is evidence that media's framing of politics as a game of strategy, as 'jockeying for position', contributes to popular mistrust of politicians (Cappella & Jamieson 1997, de Vreese 2004).

Medialization varies between countries

A study of front-page election campaign coverage in leading Swedish, American and Spanish newspapers found that politics is portrayed differently in the respective media systems. On a general level, framing of politics as a game or contest dominated 51 per cent of the Swedish material, compared to 67 per cent of the American and 52 per cent of the Spanish (Strömbäck & Dimitrova 2006, Strömbäck & Luengo 2006). The study also found significant differences in the frequency of different kinds of framing on newspapers' front pages (Table 2.3).

The most notable differences concern the framing of politics as a race for votes, as strategy, and as conflict. American newspapers were much more inclined to frame politics as a race and as strategy, whereas Spanish papers were significantly less likely to frame politics as conflict. Sensationalism in campaign coverage was infrequent in all three countries.

The Spanish newspapers also differed in that they applied a news management frame quite often, compared to Swedish and American newspapers. Somewhat surprisingly, American newspapers were less inclined to focus on the private lives and personality traits of individual politicians, albeit the

Table 2.3 The framing of politics in Swedish, American and Spanish election news coverage.

Frame	Percentage		
	Sweden 2002	USA 2004	Spain 2004
Sensationalism frame	8	1	8
Horse race frame	52	67	30
Political strategy frame	30	63	50
News management frame	9	4	17
Politicians as individuals frame	28	21	25
Conflict frame	44	52	26
Number of articles	173	117	118

The study includes front page articles in three Swedish newspapers (Dagens Nyheter, Svenska Dagbladet, Aftonbladet), three U.S. newspapers (New York Times, Washington Post, USA Today) and three Spanish newspapers (El Pais, El Mundo, ABC) during the last three weeks prior to the latest national election in each country. The frames were coded on a presence/absence-basis, and several different frames could be present in the same article.

Source: Strömbäck and Dimitrova (2006), Strömbäck and Luengo (2006).

differences were rather slight. Clearly, it was common in all three countries for journalists to frame politics as a game or contest – but much more so in the USA than in Sweden or Spain.

Opinion polls

Modern political news reporting often includes the views of ordinary citizens. Often, the views of citizens are presented in the aggregate, in the form of the results of public opinion polls. The tabloid press often allows members of the general public to rate the various party leaders' performance in television appearances. Otherwise, journalists tend to cast members of the public as cases, plaintiffs, victims, outsiders and skeptics (Strömbäck 2001, Nygren 2001).

Opinion polls are very useful when it comes to framing politics as a game or contest. They are a kind of political version of the sports journalist's score sheets. Sweden was, as it happens, one of the first countries where the media started making use of opinion polls (Petersson & Holmberg 1998, 2006).

In Sweden, most of the 'barometers' of party preference are commissioned by various media. The media thereby play a triple role in connection with polls: they commission them and then report and interpret the results. In connection with the election of 1998, newspapers *Dagens Nyheter*, *Svenska Dagbladet*, *Expressen* and *Aftonbladet*, and television news programs *Rapport*, *Aktuellt* and *tv4 Nyheterna* published 98 reports of opinion polls in the last three weeks before Election Day, ten more than in the next election in 2002. In most cases the polls measure party preferences, but evening tabloids (e.g., *Expressen* and *Aftonbladet*), commonly ask »who won the debate« or how the various parties fared, for example, in a party leader interrogation. Swedish newspapers have also started publishing daily measures of trends in public opinion (tracking polls). In the two most recent elections both Stockholm morning papers, *Dagens Nyheter* and *Svenska Dagbladet*, have published this kind of measurement in collaboration with two Swedish polling institutes, Sifo and Temo.

Opinion polls readily make interesting copy. Besides fitting into and facilitating the framing of politics as a contest, they are essentially dynamic, offer drama, and are definitely news. With access to fresh polling data, journalists are able to report, interpret and speculate about the results, the factors behind them, and the possible consequences. They offer the journalist a »quasi-objective« and proactive role as interpreter of the campaign (Lavrakas & Traugott 2000, Johansson 2001).

The media's need of changes that consist of events that are perceived as solid news, coupled with their need of a reasonable amount of control over the journalistic content, explains why they are so interested in framing politics as a contest and in opinion polls. True, the parties take stands, launch proposals and send up 'trial balloons' throughout the campaign, but the novelty is generally more in the packaging than in the contents. Since journalists actively seek to avoid being used as megaphones by the parties, they resist covering all too many of such initiatives.

In the USA, this resistance on the part of journalists has been formulated as a rule of 'product substitution': the more the Presidential candidates try to control and steer the content of campaign coverage, the more journalists go out of their way to report something else entirely (Zaller 2001). One such topic is the 'game' of politics. By framing politics as a game and taking their starting point in opinion polls, journalists can maintain a greater measure of independence and a more active role in the campaign.

The differences noted between countries caution against drawing any far-reaching conclusions. In an international perspective, the press displays considerable variation regarding the extent to which Page One news items report events and proposals initiated by the parties. A study of front-page articles in *Dagens Nyheter*, *Svenska Dagbladet* and *Aftonbladet* in the 2002 campaign revealed that 27 per cent originated in initiatives taken by political actors. The corresponding share in the USA was 48 per cent, and in Spain, 63 per cent (Strömbäck & Dimitrova 2006, Strömbäck & Luengo 2006).

One interpretation of this finding is that the Spanish newspapers follow their parties' agendas comparatively closely, but also frame politics in terms of the issues because the papers, in keeping with the polarized pluralist model, reflect the partisan front lines in society. The American papers fol-

low the campaigns closely and frame politics as a 'race' in order to avoid accusations of partisanship. The Swedish newspapers underline their independence of the parties by choosing not to report all the various campaign initiatives, instead making their own evaluations of newsworthiness – with the result that the focus can rest on both the issues and the notion of politics-as-game.

The framing of politics as a game and the frequent use of opinion polls mean that election news journalism actively contributes, if not necessarily deliberately, to the identification of 'winners' and 'losers'. Politics is both contest and the issues, and there is good reason to approach politics from both angles, but when the the framing of politics as a game begins to dominate, the issues tend to get crowded out of the spotlight. The information value of the coverage diminishes if the prime focus rests on 'the race'. Opinion polls also give rise to a certain atmosphere of suspense and expectations, both of which in themselves can, in turn, be objects of campaign journalism.

The media's extensive use of opinion polls also raises the question of the value of poll results. In the case of »who won the debate« and evaluations of how the parties fared when 'grilled' by journalists, the measurements often start while the debates and interrogations are still under way, and even when they have ended, respondents are asked to form an opinion before they have had time to reflect. Non-response in these kinds of polls is often high. The media often neglect to report the statistical details of their surveys, details that are needed to assess the value of the data presented.

Guidelines published by the World Association of Public Opinion Research (WAPOR) admonish the media always to report who commissioned the poll, the population of the study, the number of respondents, the interval during which the data were gathered, the sampling technique and method of data collection, and the exact formulation of the ques-

tions put to respondents. Furthermore, the margins of confidence should be specified. The media's reporting of the technical data surrounding field research data often falls short of the WAPOR guidelines. Who commissioned the study and who executed the survey are generally mentioned, but information about the population, sampling, data collection, the formulation of the questions and systematic sources of error is often lacking.

Increasingly fickle voters and weaker party identification mean that prognoses necessarily become less certain. Experience has shown that barometers of party preference are seldom exact enough to allow conclusions as to trends in opinion. Several factors contribute to a decline in the quality of opinion polls in recent years. Declining election turnouts mean that different demographic and political groups' propensity to vote assumes greater importance; unfortunately, most polls ignore this aspect. Keener competition among polling institutes and short turnaround times lead to shortcuts in the field work and follow-up. Widespread use of mobile telephones and unlisted numbers also inflate the frequency of non-response in telephone surveys. Attempts to adjust data to compensate for non-response on the basis of responses to past surveys have proven problematic (Pettersson & Holmberg 2006).

Thus, it is not surprising that measures of party preference are so uncertain. Our conclusion is that the barometers of party preferences have come to play a highly exaggerated role in both political journalism and public discussion of domestic politics as a whole.

The struggle for control over the agenda

The relationship between the media and the parties is essentially antagonistic and boils down to a power struggle (Cook 1998). Contradictory views as to what should be given attention and how it should be treated result in a struggle for control over the agenda, the power to frame and to formulate problems. The political parties want to draw the public's attention to the areas where they consider themselves strongest and their opponents weakest. The media, for their part, want good news copy that arouses their readers', viewers' and listeners' attention and interest, while they also are keen to maintain their editorial independence. The antagonism between the media and the parties manifests itself in different ways in different countries, depending on prevailing journalistic norms and values, the political culture, and the structure of the media and party systems and how they are inter-related.

In Sweden, journalists have acquired the power to decide how much politicians will be allowed to speak in their own words, and in what contexts their words will be framed. The average length of uninterrupted speech (sound bite) in Swedish television news is 15–20 seconds (Asp 1995, Jönsson & Strömbäck 2007). In the campaign of 2002, politicians were quoted an average 12 sentences per article and 10 sentences per broadcast news item, which was less than in the preceding election four years earlier (Strömbäck 2004). Sound bites on Swedish television are, however, longer than sound bites on American television. There, the average sound bite today is less than 10 seconds, having shrunk from about 40 seconds in the late 1960s (Hallin 1992, Lowry & Shidler 1999).

In Swedish journalists' eyes, 'objectivity' largely means going beyond politicians' statements to »the hard facts of a political dispute« (Pettersson 1998); at the same time, political

debates are about precisely which facts and which interpretations are relevant. The interpretation of 'objectivity' most American journalists subscribe to is that they, as equitably as possible, report the different sides of a controversy or issue. Thus, Swedish journalists have a more activist ideal of journalistic practice than their American colleagues.

According to the classic news formula, news journalism should answer the questions: who, what, when, how and where. Different types of interpretive journalism have become increasingly common, however (Djerf-Pierre & Weibull 2001, Strömbäck 2004, Patterson 1993). This reflects the media's growing unwillingness to serve solely as arenas. Instead, the media strive to be more autonomous and active, preferring to interpret rather than merely describe. Interpretive styles of reporting enhance the power of journalists by giving them more control over the content of the news (Blumler 1997, Patterson 2000),

Interpretive journalism is not only a question of power. It is also a matter of journalists' strivings to explain 'why' and to make reality intelligible to their audiences in ways that strictly descriptive journalism cannot. Consequently, interpretive journalism is also a way to enhance the information value and the appeal of the content journalists produce.

What all forms of interpretive journalism share in common is that they are analytical and often speculative rather than purely descriptive. Some of the more commonly practiced forms are speculation, critical expertise and partisanship.

Speculation

One form of interpretive journalism is making predictions. An analysis of news coverage of the election campaign of 1998 found that speculation about the possible consequences of an event and speculation about the likelihood of a fu-

ture event are very common in both print and broadcast media (Strömbäck 2001). This means that election journalism more and more discusses what may happen rather than what has happened (Ekecrantz & Olsson 1994).

Half of the articles and items in the campaign of 2002 contained speculations of some kind. At best, they are based on expert knowledge and insight, so-called 'educated guesses', and thus can help readers, viewers and listeners orient themselves. But they may also be pure guesswork and a product of the journalist's desire to create a gripping story, i.e., to add an element of drama to a situation, where none yet exists (Strömbäck 2004).

Expertise

In another form of interpretive journalism, journalists assume the role of expert, and journalists interview their colleagues in place of a knowledgeable person from outside the organization (Djerf-Pierre & Weibull 2001). This kind of interpretive journalism, known as 'metajournalism', seldom treats the substance of politics, but nearly always discusses politics as a game, with a particular focus on politicians' strategies and ulterior motives, asking who stands to gain and who stands to lose (Neveu 2002).

Metajournalism characterized 10 per cent of the articles and news items about the campaign of 2002. The news analysis offered on television commonly discussed politics in terms of game strategy, and the journalist/commentator always assumed an interpretive stance. In the case of the press, the picture is more mixed. Here politics was portrayed as a game in 68 per cent of the articles. Other studies have found that even in off-election years the news analysis offered by public service television (Rapport on SVT1 and Aktuellt on SVT2) nearly always frame politics as a game, that the comments are often interpretive and express valuations, and that the commen-

tators seldom explain what they base their conclusions on (Lundell & Olson 2005).

Advocacy

Interpretive journalism can also mean that journalists abandon their neutrality and take a position (Djerf-Pierre & Weibull 2001, Strömbäck 2001). It is not necessarily a question of political partisanship, i.e., that the journalist explicitly takes a stand on an issue or favors a particular party or politician. More commonly, it is a matter of questioning various political actors' actions or personal qualities, such as competency or character.

Interpretive instead of investigative

Altogether 43 per cent of the items and articles in the campaign of 2002 expressed an interpretive stance; this is a slight increase compared to the election of 1998. This attitude is expressed most frequently in *Expressen* and *Aktuellt*, and least often in *Dagens Nyheter* and *Aftonbladet* (Strömbäck 2004).

A comparison of front-page articles in the Swedish, American and Spanish press found the interpretive style of journalism to be more common in Sweden (45 per cent) and Spain (43 per cent) than in the USA (6 per cent). Once again, it seems that Swedish journalists are imbued with an active and independent attitude, at least in the lead stories relating to elections in leading nationally distributed newspapers.

Interpretation is more common than investigation and scrutiny. Although numerous studies among journalists have found that scrutiny – the famous ‘watchdog function’ – is one of the most important tasks of journalism (Djerf-Pierre 2001), it is rather rare in the last weeks before Election Day

for the media to call politicians to account for what they have done or failed to do in their past term in office. If a criterion of investigative scrutiny is that it be based on verifiable facts, then less than one per cent of the articles and items in 2002 scrutinized Government policies during the four preceding years (Strömbäck 2004).

One reason why investigative reporting is so rare, at least in the final days of the campaign, may be that it is so demanding of time and resources. Another possible explanation is that the media during campaigns are more oriented toward the future than toward 'history'. Even party leader interviews are mainly about the future and the parties' promises rather than what the parties did or did not do in past years.

Election coverage in the form of both party leader interviews and news reporting live, so to speak, in the shadow of the future. Mainly the present and immediate future are considered interesting and relevant; finding fault with those who have had political power the past term is not.

In one sense the media leave politicians considerable room for maneuver by not following up and demanding accountability of those in power. Journalists also let the agenda consist of promises, ambitions and future scenarios. In another sense, the media have retained or strengthened their grip on the agenda and on interpretive privilege. This is reflected in interpretive journalism, independence in news selection, framing, speculation, opinion polls and framing politics as a game or contest.

There are some tendencies toward an increase in 'soft news' and entertaining features in election journalism as a response to ever keener competition for the public's attention. The changes should not be exaggerated, however, and they need not imply any decline in the information value of coverage on the whole. A study of campaign journalism leading up to the elections of 1982, 1991 and 2002 found that whereas

the degree of information-density in campaign coverage rose somewhat higher in 2002, the breadth and depth of the information offered was less (Johansson 2006).

Unquestionably, however, election journalism has moved from fact-filled toward more dramatized information, to use the terminology of Figure 2.3. The changes mean that the information that media offer during the campaign has a stronger appeal, but also that it is somewhat less informative (Johansson 2006).

3. The Parties' Campaign

»Thus, the main impression, both as regards the party names and the names of individual politicians, is that negative attention, polemics, predominates« (Westerståhl & Särilvik 1956: 188).

An analysis of the op-ed columns of the party press in the campaign of 1954 found that the political debate in the media not only followed party lines, but it was also predominantly negative. Political scientists Jörgen Westerståhl and Bo Särilvik remarked especially about the »enormous interest« Liberal Party leader Bertil Ohlin inspired in Social Democratic editorial writers. They wrote: »One cannot help wondering whether this great interest in the Opposition parties and their leaders may not cut two ways.« Might it not give readers the impression that the objects of such interest must be »interesting«? And, noting a difference between papers with particularly homogeneous readerships and others, they wondered what effect it might have on readers (Westerståhl & Särilvik, op. cit.).

Thus, fifty years ago there was already research-based concern about the ability of the political parties to communicate with voters via the media. In reality the media are the most important channel between voters and their elected representatives, but the media had gradually become political actors in their own right, with a logic of their own. The media's image of politics is created in an interplay and a contest among the media and between the media and others, where many actors vie for the power to set the agenda and frame the issues of the day.

The parties and the candidates have always been, and continue to be, central players, but they are not alone on the field. The competition in a medialized public sphere is growing ever keener, and many other organized interest groups are also trying to steer the political agenda. These include professional lobbyists as well as voluntary organizations and activist groups. New technologies, and the Internet in particular, have also altered the conditions for influencing public opinion.

Political parties in medialized democracy

In representative democracies the people elect their representatives, and in most democratic countries it is the political parties who are responsible for recruiting and launching the candidates among whom voters make their choices.

Parties sustain democracy in other respects, as well. In a previous report the SNS Democratic Audit summarized social scientists' views on the role of the parties in democratic societies (Pettersson, Hernes, Holmberg, Tøgeby & Wängneryd 2000). Parties are to articulate political points of view, be receptive to and convey new currents of thought and opinion in society, and formulate political ideas. In this connection they aggregate opinions and weigh together different interests and perspectives to form a coherent and practicable set of policies. Parties are also expected to activate the citizenry and stimulate the free exchange of ideas and vital, ongoing public discourse. In a representative democracy like the Swedish, parties channel public opinion and convert 'the will of the people' into political action. Finally, parties fulfill an important function by recruiting and training new members in democratic procedures.

Thus, some of the roles parties play are fundamental and immutable over time. At the same time, there are major vari-

ations when it comes to organizational aspects and decision-making, etc. The party system has changed considerably over time. As in many other Western countries, Swedish parties are facing serious problems due to weakening party identification, shrinking membership, increasingly fickle voters and growing mistrust of politicians. At the same time, the parties' financial, organizational and professional resources have increased (Holmberg 2000, Nord & Strömbäck 2003). The research community worldwide has examined, and frequently expressed concern about, the health of the parties. One central theme in such discussions is the parties' dependence on mass media and the increasing medialization of politics.

Politics and journalists: mutual dependence, but conflicting interests

That the dependency relations between politics, media and politicians are mutual is quite clear: the parties need the media to reach out to voters, and journalists need politicians as news sources. But the relationships are far from harmonious. One source of tension and conflict are the expectations regarding the respective groups' roles and functions. Journalists are expected to critically examine the performance of those in power. Politicians, for their part, are expected to use the media strategically so as to maximize positive exposure of themselves and their parties in the media. These respective ambitions are clearly at odds. There is no consensus as to which of the groups has the upper hand at present, but viewed in the longer term, journalists have gradually extended their influence vis-à-vis the parties.

The theory of two campaigns

The findings of a study of Swedish parties' campaign planning in the 1970s were summarized in a theory that posited that the period leading up to an election actually consisted of two distinct campaigns (Koblik 1980).

The principal concern in the first campaign was to mobilize the party's core voters. This mobilization phase, which lasted into the summer months before the election (held in September), was primarily introverted. It focused on the party's fidelity to its ideas and symbols. The second campaign, which took place in the final weeks before Election Day, sought to reach out to new, swing voters, primarily by initiatives designed to manipulate the media's agenda. Whether or not a party was successful depended on its ability to peak at the right moment (Koblik 1980).

This theory reflects the thinking of party strategists roughly three decades ago. Some concepts and frames of reference are still current, but much has also changed. 'Core voters', for example, are nowadays an endangered species, whereas swing voters have become so many that party strategists target them long before the final weeks of the campaign. Media are even more important in the parties' campaigning today. Particularly in the USA one may well speak of a permanent campaign (Blumenthal 1980, Ornstein & Mann 2000).

Adaptation to the logic of the media, and then...?

The studies carried out by media researcher Kent Asp on the relationships between the media and political actors in Swedish election campaigns in the interval 1979–2002 show that politics has gradually been medialized (Asp 2003). That is to say, politicians and other actors that have dealings with the media adapt to the way the media work and to the media's requirements.

When the media attained their position of autonomy in the 1960s and 1970s, they gained the upper hand vis-à-vis the parties and took the initiative. During the 1980s politicians have adapted their behavior with regard to publicity-seeking to the logic of the media. In the 1990s, politicians have learned how to use that logic to their own advantage. Asp concludes that in a long-term power perspective, all actors in the public sphere – media included – have adapted to the logic of the media (Asp 2003).

When the logic of the media has become all-pervasive, it is difficult for any individual to steer the current of debate. Neither politicians nor journalists have the upper hand at present. An important change since the 1990s is an intensification of the struggle for public attention. This development, which has affected both the media and politicians, has to do with the ongoing proliferation of media and the consequent fragmentation of the audience. The tempo in radio and television has also speeded up. In sum, a greater number of actors compete in a greater number of increasingly differentiated channels. Fewer watch or listen to any given medium at any given time, and they no longer devote their undivided attention to what they see and hear. The struggle for attention is intensifying.

Interviews with the parties in connection with the election of 2002 showed that the greater number of media has changed how time is used (Nord & Strömbäck 2003). The number of genres, programs and channels that the parties are expected to appear in has increased dramatically during the 1990s. These range from the news columns of newspapers to 'round-the-clock news channels and appearances in studio sofas. This trend increases the pressure on politicians and journalists alike. At the same time, the intensification and medialization of campaigns appear to have reduced the predictability of campaigns for both groups. Visibility is an important prerequisite to the parties' success, but visibility is increasingly hard to control.

Keener competition for the public eye

One of the driving forces behind the growing competition for attention in election campaigns is the presence of other actors than the traditional protagonists, journalist and politician. Many organized interests, including branch organizations, corporations and public institutions and authorities try to influence political information flows, under election campaigns, too. A significant expansion of the public relations and lobbying branch has transformed the public sphere.

In Sweden most of this expansion has taken place in the span of the past fifteen to twenty years. An inventory of the Swedish PR and information branch in 2004 identified some 1000 PR consultants in companies that together had revenues of over one billion SEK (over 110 million euro). The branch as a whole employs 6–8,000 people (Larsson 2005a, 2005b) in a workforce of about 5.4 million.

The ethic and modus operandi of the PR branch are essentially American. PR and so-called »strategic issues management« have become a profession – and an object of research – in their own right. The strategies and theories that predominate in the branch have evolved into a political culture that differs markedly from Swedish tradition. In an American context, corporate intelligence and public relations often have to do with managing adversarial and confrontational relationships, e.g., vis-à-vis activist and extraparliamentary movements (Heath 1997). In the Swedish model, social phenomena like environmentalist and feminist movements have traditionally been incorporated into the established party system.

Public relations in politics

Influencing public opinion and lobbying are as yet a relatively minor focus in the Swedish PR branch (Hermansson, Lund, Svensson & Öberg 1999). Most of the PR consultants who are involved in this work have first-hand experience of

politics and know how politicians think. They generally have a personal network among politicians and party officials; many have first-hand experience of election campaigning, which has endowed them with practical know-how when it comes to the logic of the media, news values and crisis management.

A personal background in politics is clearly an asset for any political PR consultant. At the same time, Swedish PR consultants play a very limited role in election campaigns, as the parties prefer to manage them on their own.

Although the number of political consultants is small in relation to the branch as a whole, they definitely have achieved a presence in Swedish politics. Politics – during election campaigns and otherwise – has more and more become a matter of strategic communication. The American experience, which came earlier, has influenced political marketing in practice as well as the research relating to it. In the USA, election campaign planning is handled by PR professionals with expertise in persuasive communications, public opinion, media planning and political marketing. The phenomenon is often characterized as »the professionalization of politics«.

The term, 'professionalization' is used in many different ways (Negrine & Lilleker 2002). In some contexts professionalization refers to the emergence of a category who work in politics and who have specialized training in managing campaigns (Larsson 2005a). Sometimes the term is used to describe situations where campaigns are managed by politicians working on salary full-time throughout the campaign instead of by campaign volunteers. Yet other times the word refers specifically to the use of independent political consultants and 'spin doctors' in the campaign. In a fourth usage, 'professionalization' refers to the use of certain campaigning techniques, namely, those usually included under the heading of so-called political marketing.

Professionalization in this last sense, »professional elec-

Spin doctors united

»Spin doctor« is American jargon for those who are experts at »putting a spin on« a message, image, etc. The metaphor comes from »putting a spin on a ball«, a well-known concept in sports like baseball. Players put a spin on a ball to achieve a tactical advantage; likewise in public relations.

The use of public relations consultants in politics has become so pervasive that the branch has become a profession in its own right, replete with branch organizations, specialized professional training and periodic conferences. A visit to one such conference provided interesting insights into the realities of American election campaigns (Petersson, Holmberg, Laurin & Strömbäck 2005).

Those who are fairly well-versed in contemporary American politics would find much of the conference familiar, but there are a few aspects, emphases and recent changes that are worthy of note.

What was missing. It was striking how little the parties as such came up in the discussions. Furthermore, the conference was devoted virtually entirely to the formal aspects of politics, to tactics and strategy, whereas the substance of politics, the issues, were basically ignored. There was no discussion of ideologies, albeit one or another speaker did mention that ultimately, a candidate is an exponent of certain fundamental values.

What there was more than enough of. Prerequisite to a successful career in American politics is access to money, money and more money. The focus rested nearly always on individuals – the individual candidates – whereas groups and collectives were basically cast in the role of 'extras'.

The market rules. The expression, »political market« is sometimes used as a metaphor, but here it is brutal reality. In the world of consultants politics boils down to buying and selling. Although several speakers pointed out that there are important differences between political and commercial marketing, there are also major similarities. Target audiences, media strategies and advertising budgets apply as much to election campaigns as to selling beer.

Little respect for the voter. Hardly any speaker could be accused of thinking too highly of the American voter. On the contrary, most speakers stressed that the American public, and especially those who have not yet made up their minds toward the end of the campaign, don't care, know very little, and pay little attention to politics. Therefore, it is unwise to approach them with factbased arguments and boring details; instead the aim should be to arouse their feelings and spark an impulse. Emotional rather than rational factors decide an election. A few speakers deviated from this pattern, particularly those who described the Dean campaign and web-based mobilization of campaign volunteers. By and large, however, the consultants expressed a condescending attitude, verging on contempt, toward the average voter.

A man's world. There were women among the participants, perhaps as much as a quarter, but the speakers were all men. Political consulting in the USA is obviously still a male domain, demographically, rhetorically and intellectually. Metaphors drawn from war and sports are very common, the jargon is often cynical and 'tough' – at times parodically American. All in all, although consultants are hired to come up with solutions, they seem in fact to be a good part of the problem with American politics.

tion campaigning«, may be measured in terms of the use of certain techniques (Nord & Strömbäck 2003):

- * Strategic use of opinion polling (internally to monitor views and voter mobility and externally to generate news stories, provided the party can gain by it);
- * Use of focus groups (in order, before 'going public', to test proposals and ideas on strategically selected groups under the leadership of trained facilitators);
- * Segmentation of the electorate into target groups, based on demographics and lifestyle;
- * Adaptation of messages and their delivery to appeal to given target groups;
- * Media strategies (adaptation to the logic of the media, creating news value by, for example, arranging events with an eye to attracting media attention or giving selected media 'exclusive' political information);
- * Strategic media selection (based on a typology of media according to their respective readerships, audiences and users);
- * Evaluations of the party's (and other parties') strengths and weaknesses, before, during and after the campaign;
- * Non-stop campaigning with continuous planning and evaluation of campaign activities.

In order to avoid possible confusion due to the many uses of the word 'professionalization', we choose to summarize these techniques with the term, 'political marketing', reserving 'professionalization' for reliance on political consultants and 'spin doctors' in campaigns.

The growth of the PR industry is a fact, but its implications for democratic processes are still hotly debated (Hermansson, Lund, Svensson & Öberg 1999). Supporters of the PR industry, both in the research community and among practitioners, consider public relations one of the fundamentals of pluralistic democracy. Public relations lubricates the democratic machinery, facilitates communication and understanding and makes for more effective decision-making.

Critics of the PR industry see instead that the PR industry gives certain groups and actors the opportunity to manipulate the democratic system. Information is published so as to mobilize or demobilize segments of the public in order to further certain interest groups' strategic objectives without revealing their identities. Turow (1997) has accused the advertising industry in the USA of »breaking up America« into market segments and target groups. Several of the authors in the anthology, *Mediated Politics* (Bennet & Entman 2001) speak of the problem of applying marketing philosophy to the realm of political ideas and opinions, pointing out that it excludes broad segments of the population who are of no interest to politicians, the media or advertisers from public discourse. Market-oriented journalism and politics means, in practice, the disenfranchisement of certain groups of citizens. Non-voters and groups with little purchasing power are left out of public discourse and of democratic politics.

Medialization, professionalization and modernization

Despite, or perhaps because of, its diffuse character, the concept of professionalization is central in virtually every description of the historical evolution of election campaigning. The international research literature contains numerous, strikingly congruent histories that also take the interaction with mass media into account (Blumler & Kavanagh 1999; Farrell & Webb 2000; Norris 1997, 2000; Plasser & Plasser 2002). Researchers are more or less agreed on the identification of three main types of election campaigns over the past century: the pre-modern, the modern and the post-modern (Figure 3.1).

In the pre-modern campaign, which dominated until the 1960s, the political parties controlled the communication system through the party press and loyal voters. Political rhetoric consisted of presenting messages in keeping with the party program – that is, of advertising the party platform.

The modern election campaign was common from the 1960s to the 1990s and was heavily influenced by the emergence of television as the most important medium of political communication. Journalism was professionalized and grew more independent of politics; meanwhile, critical scrutiny of power centers in society became an important part of journalists' professional code. As a consequence, parties adapted their activities and communications to the logic of the media. Political rhetoric – communicated mainly via the media – had the objective of selling a message to the voters. Party leaders' ability to »manage impressions«, individual candidates' personality and image, and an ability to create media-friendly happenings and events became crucial to success in reaching mass audiences.

The third category, the post-modern campaign, is still in its infancy. Its principal characteristic is a proliferation of channels and a fragmentation of the public. A great number of

	Premodern campaigns	Modern campaigns	Postmodern campaigns
Type of political communication system	Party centered	Television centered	Fragmented: multiple channels and media
Predominating political rhetoric	Messages according to party programs: propaganda for party ideology	Sound bites, image and attention: selling of politics	Messages according to target groups: marketing of politics
Principal media for political communication	Party press, posters, leaflets, newspaper ads, radio broadcasts	National newscasts in television	Targeted messages in specific TV programs, targeted mail and email
Principal channels for political messages	Ads, posters, leaflets, rallies, radio speeches	National TV spots, mass mailing, campaign posters, magazine ads	Targeted TV spots, email campaigns, telemarketing, internet ads
Target groups	Social categories and classes	Entire electorate	Segmentation, specific voter groups
Campaign coordination	Political party executive and headquarter	Party campaign managers, external experts on media, advertising and polling	Separate campaign units with parties, more specialized political consultants
Preparation	Short-term campaign, ad hoc	Long-term campaign	Permanent campaign
Campaign finance	Low budget	Rising costs	Increasing cost spiral
Electorate	Class voting, stable voters	Erosion of party loyalty, increasing volatility	Volatile voters, issue voting
Campaign logic	Party logic	Media logic	Market logic
Type of party	Membership party	Campaign party	Market party
Political party philosophy	Product orientation	Sales orientation	Market orientation

Source: Summary of typologies in Plasser & Plasser (2001) and Norris (1997 and 2000); cf. also Dörner & Vogt (2002). Classification of political party philosophy based on Jennifer Lees-Marshment's categories (Lees-Marshment 2001 and 2004, Lilleker & Lees-Marshment 2005).

Figure 3.1 Three types of election campaigns.

news media, different genres and channels operating 'round the clock address different audiences. The growth of the Internet adds to the proliferation/fragmentation. In order to reach ever-more mobile and elusive groups of voters the parties resort to ever more sophisticated techniques of political marketing, e.g., opinion polls and target group-tailored messages. Party policies are formulated only after a detailed inventory of the preferences of the 'voter market'. Political rhetoric has the aim of selling the party's policy to selected segments of voters. Professionalization of election campaigns means that campaigns are led by external PR experts and political consultants. The negative tone in media messages is in part a response to the increasingly sophisticated techniques politicians use to manage the news, strategically planned events, and spin control.

Pre-modern campaigns are run according to the logic of the party. Since campaign work is labor-intensive, members and campaign volunteers rally to the cause. Modern campaigns are run according to the logic of the media; the parties are transformed into campaign organizations and staffed with individuals having proven communicative competence. The post-modern campaign is steered by the logic of the market. The parties adapt their policies to the tastes and preferences of selected target groups. High costs for marketing mean capital-intensive campaigns. The three kinds of campaigns differ in more ways than technique and methods. They also differ fundamentally with respect to their conceptions of politics, parties and voters (Lees-Marshment 2001; cf. Newman 1994).

Product orientation, which dominates the pre-modern campaign, means that the parties first formulate their »product«, their policy in, for example, a campaign platform and the party program. The purpose of the campaign is to follow up and advertise the product.

Sales-oriented parties also start out by formulating a policy, but they make use of more sophisticated methods to get

their message across. By means of opinion surveys, strategic choices of media and formulations of campaign messages, the campaign tries to arrive at the »best« way to reach out to voters and win their support.

The market orientation, which characterizes the post-modern campaign, means that the party starts out by studying 'the voter market' and the party's opponents and charting the political landscape. Only thereafter do they formulate their policy (Lees-Marshment 2001, cf. Newman 1994). The party goes on to monitor the 'voter market' by means of repeated opinion polls, adjusting its 'product' to suit popular preferences as necessary. In short, the party behaves much like a commercial manufacturer. Use of political marketing techniques is a necessary (but not sufficient) indicator of a market orientation.

This typology of election campaigns is, of course, a simplification, and it is primarily based on observations made in the USA and Great Britain – both essentially liberal media systems. The question is, to what extent is it applicable to countries having other media systems – like, for example, the countries of Fenno-Scandinavia?

Americanization?

Modernization, professionalization and marketing orientation – all three are often described as central features of what is often referred to as »Americanization«. American campaign culture and American politics are usually a reference point in international comparisons and therefore influence thinking about election campaigns the world over. The question is, though, whether there is any basis for the notion of 'Americanization' of election campaigning outside the USA. Do we, for example, find any indications of an ongoing Americanization of Swedish election campaigns?

In our work to answer this question we took our starting point in previous research that has studied the phenomenon in Sweden and in the rest of Fenno-Scandinavia (Åsard & Bennett 1997, Håkansson 1999, Jönsson & Larsen 2002, Nord & Strömbäck 2003, Karlsen & Narud 2004) and in other parts of the world (Swanson & Mancini 1996, Plasser & Plasser 2002, Norris 2000, Blumler & Gurevitch 2001).

Americanization: one word, many meanings

A review of the literature quickly turns up a number of problems that make comparisons difficult. First, there is no agreed definition of the concept; different researchers focus on different aspects of the campaign culture.

One dimension in the analyses of tendencies toward Americanization is the medialization of politics. Medialization means, in the first place, that politicians adopt the logic of the media in their rhetoric, which is said to result in more polemics, more negative messages, and less concreteness (i.e., the parties talk less about principles, visions and concrete proposals and rely more on simple slogans) in what they say.

A second aspect of medialization relates to political journalism and focuses on the space allotted to election campaigns and politics in newspapers, radio and television, but also the image of politics offered. The tabloid press tends to give politics and election campaigns less and less attention. The image of politics conveyed is increasingly polarized (a higher level of conflict, criticism and negative messages), popularized (the campaign is characterized as a contest, a race, a drama and substantive issues tend to be left aside), and personified (a focus on individual candidates, their images and personalities).

The second dimension of Americanization relates to political marketing. Here the focus rests on factors like the degree of professionalization and use of public relations consultants

in the campaign, the voter focus (whether the entire electorate or selected segments), the parties' communication strategies (use of journalist-steered or non-journalist steered channels of communication) and the basic philosophy underlying the campaign (sales or market orientation).

A third dimension that researchers discuss is the structural framework surrounding campaigns in different countries: the legal, economic and social conditions that apply. Factors of interest here are the party and election systems, party financing, geographical extent of the campaign (regional or national), voters and voter turnout, and the media structure (opportunity to advertise on television, the character and position of the press, whether television is commercial, public service, and so forth).

Yet another problem that makes it difficult to compare is the fact that the analyses focus on entirely different time spans. Some researchers describe developments during the entire twentieth century. In these cases the focus often rests on the transition between the pre-modern and the modern phase of campaigning, and medialization is held forth as the most salient sign of Americanization. Others focus on differences between campaigns in the 1990s and on the increasing market-orientation of politics. In these latter cases, medialization and its effects on politics are taken for granted, being considered to have taken place in an earlier phase of development.

On the basis of these considerations we have chosen to analyze the change in Swedish politics in recent decades in terms of three dimensions. The first has to do with medialization; the second, political marketing; and the third, the structural conditions under which Swedish politics operates.

Figure 3.2 summarizes our analysis of tendencies toward Americanization in Swedish politics in recent decades. Our conclusion is that there is little evidence of Americanization, with the possible exception of the frequency of personifica-

tion in political journalism, the use of certain techniques of political marketing, and, to a lesser extent, the use of professional consultants.

Medialization

When we look for signs of medialization of politics in Sweden, the main feature is an increasing personalization of politics in political journalism. A study of the campaign advertisements of the Social Democrats, the Liberals and the Conservatives in newspapers in the period 1998–2002 shows that the focus on the party leader has increased markedly in party-controlled campaign material during the 1990s. (M Johansson 2005). The focus on candidates (other than the party leader) has, on the other hand, decreased. All in all, the parties' own rhetorical focus has become more person-fixated.

When we examine polarization and popularization of political rhetoric, we find few signs of greater medialization. The parties' messages are no more negative today than previously (M Johansson 2005). Instead, negativism has varied from campaign to campaign and between parties, but not in any systematic fashion. Nor are there indications that the parties' messages have become more diffuse or vacuous.

Neither does a study of the party platforms find any changes in the parties' rhetoric. A comprehensive analysis of the rhetoric used in party platforms and party leader debates between 1948 and 1994 found no long-term trends. The variations noted are specific to certain individuals and certain campaigns, but also to the parties' traditions. The Center Party (Agrarian Party in the earlier years studied) displays a calm and reasoning manner of expression with few polemical features and a good number of issues on its agenda. There is no indication of 'medialization' of the parties' campaign rhetoric. If anything, polemics has become less common over time. Polarization has become less pronounced, not moreso (Håkansson 1999).

Figure 3.2 Americanization of Swedish election campaigns?

The American model	
Dimension 1: Media bias of politics	
Bias of political rhetoric: polarization, popularization, personification	Polemics, negative messages, personification and less facts, »issues«, »substance«
Media bias of political journalism, attention to campaigns, image of politics: poralization, popularization, personification	Less attention to election campaigns, strongly polarized, popularized and personified image of politics
Dimension 2: Market orientation of politics	
Professionalization, use of PR-consultants	Extensive. Consultant-based campaign management a »must«
Use of political marketing strategies.	Extensive and systematic.
Voter focus: whole electorate or narrow segments	Focus on likely voters, segmentation
Communication strategy: communication channels controlled by journalists or not	Heavy reliance on paid ad sports and direct channels to voters, direct marketing, internet and TV shows
Fundamental campaign philosophy	Market orientation.
Dimension 3: Structural premises	
Election and party system	Candidate-based, bipolar party system, presidential
Financing	Private contributions, capital-intensive campaigns, rising costs
Geographical orientation: regional or nationwide campaigns	Regionalized campaigns
Decision-making in the campaign: individualized or centralized	Highly individualized (individual candidates)
Voters and turnout	Low turnout, demographic heterogeneity
TV-spots	Paid ad spots allowed; lax regulation of media campaign coverage
Media	Television privately owned and commercially financed; declining newspaper readership

Americanization of Swedish politics? Yes or no

No. No increase in polemics, negativt messages, but a greater emphasis on individuals, greater focus on party leader.

Yes, somewhat: attention to politics and the campaign unchanged, no greater polarization or popularization of journalism, but personification and a people-vs-elite dichotomy.

No. Party leadership in control, some use of consultants.
Yes, to a varying extent.

No. Focus on all eligible voters, but growing awareness of where the party has support.

No. Political ad spots not allowed in major networks, focus on media controlled by journalists (newscasts, election coverage)

No. Sales orientation.

No. Party-based, multiparty system, but growing focus on individual candidates

No. Chiefly public funding, slight rise in costs

No. Nationwide campaigns

No. Still centralized (national party leadership)

Somewhat. High turnout, but downward trend and increasing heterogeneity

No. Campaign ads not allow in major channels. Little regulation of campaign coverage (but high standards demanded of public service channels)

No. Strong public service broadcasters, but commercial TV is expanding; newspapers still a mass medium

As for political journalism, there are no indications that politics in general, and election campaigns in particular, have received any less attention from newspapers or television in recent decades (see Chapter 3). Election programming is among the most stable genres in Swedish television. Nor does the daily press pay any less attention to politics and elections. Traditional election programs have, however, been complemented by new kinds of programs and genres, such as informal interviews and talk-shows.

Studies of the media's coverage of campaigns have, however, found an increase in the focus on individuals, and especially party leaders (Asp & Johansson 1999, Johansson 2006). Personification has increased, but there is no evidence of increased popularization or polarization. There is considerable variation between kinds of media and genres, however. Not surprisingly, political journalism in the tabloid press is generally more medialized than in the broadsheets, and among tabloid papers, medialization is more pronounced in *Expressen* than in *Aftonbladet*. In television, medialization is more common in privately owned and commercial TV4 than in the non-commercial public service channels, SVT1 and SVT2.

Political marketing

The Swedish political parties have these past five years used a variety of political marketing techniques – from focus groups and opinion polls to analyses of other parties' strengths and weaknesses (Strömbäck & Nord 2003). But they have hardly been systematic in their reliance on them, not even in the case of polling, which is the most commonly used technique. Those parties that seemed most inclined to use such techniques in the 2002 campaign were the Social Democrats and the Conservatives. The parties least inclined to use them were the Greens and the Left.

In American politics, professional, consultant-based cam-

paigned management is a given. In Sweden, campaigns are still run by the party leadership, albeit a growing number among party staff work with political marketing techniques and do so in consultation with political advisers and consultants (Nord 2006). Swedish parties still have the ambition to speak to the entire electorate. In a proportional election system like that in Sweden, everyone is a potential voter. There is a growing awareness of the socio-demographic characteristics of the party's core voters, but the typically American focus on »most likely voters« and emphasis on demographic segmentation have not made much of an imprint in Swedish politics to date.

When interviewed, journalists do sometimes give examples of particularly good media contacts and express praise of certain politicians, but on the whole reporters who cover domestic politics do not consider Swedish politicians very professional. They are not talking about the lack of marketing know-how, but rather are saying that many Swedish politicians are lacking in *savoir faire* (Nord & Strömbäck 2003).

The communication infrastructures available to politicians in the USA and Sweden, respectively, differ in important respects. American politicians have to rely on paid television air time, direct advertising and the Internet in order to reach voters. Candidates also try to make appearances on other kinds of television programs than newscasts, e.g., talk-shows and entertainment. In Sweden, political advertising is forbidden on the principal television channels. The parties still prefer to appear in journalist-steered program genres, although appearances in other kinds of programs have become more common.

No Swedish political party today can be considered market-oriented. In comparison with past studies of the market-orientation of American and British parties, the Swedish parties are hardly in the same league (Nord & Strömbäck 2003). Instead, the parties are sales-oriented, albeit to varying de-

grees. If any party showed any tendency toward market-orientation in 2002, it was the Social Democrats. The Conservatives and the Left were clearly the most product-oriented of the parties. Their campaigns were more in keeping with the respective party platforms than attuned to what the Swedish public wanted to hear. The Liberal Party, Center Party and the Christian-Democrats appeared to be sales-oriented. They did their best to sell their policies and did not change them in the face of contrary public opinion. But, rather than buck public opinion and persevere on less popular issues, they tended to play it safe and stress other planks in the platforms that they knew were supported by broader segments of the population than the party membership (Nord & Strömbäck 2003).

It is, naturally, problematic to try to draw conclusions about the parties' strategies on the basis of data from a single election campaign. A lot can change between elections. It has also been found that parties that have done poorly in an election are more apt to be more market-oriented, particularly if they have been unsuccessful in a series of elections (Gibson & Römmele 2001).

One might venture to interpret the Conservative Party's recent swing away from its traditional championing of lower taxes in an effort to develop a broader voter base as a response to the party's poor showing in the election of 2002. It might be classed as the kind of mass party that does not address any particular socio-economic or demographic groups, but rather tries to appeal to broad groupings so as to maximize its support among voters. Such parties have been termed »Allerweltparteien« or »catch-all parties« in the literature (Kirchheimer 1966). The recent turn toward ideological discipline that has taken place in the Left Party and party leader Lars Ohly's coming to grips with the issue of the party's communist past might be taken as indications of a growing product-orientation within the party leadership.

Not even the initial phases of the campaign of 2006 show

any signs of increasing professionalization of the campaigns – rather the contrary. Several parties are operating without the assistance of a public relations agency or media agent. All the parties rely on advertising agencies for help with their campaign materials; at the same time, they all play down their use of agencies and stress the importance of keeping responsibility for the content in their own hands (Leijonhufvud & Jönsson 2006).

The political structure

Neither do we find any clear-cut evidence of Americanization of the political structure. Campaign costs have risen, but so has public financing of the parties' campaigns. As for geographical scope and voter orientation, the parties still run nationwide campaigns and, for the most part, address the entire voting public. Voter turnout has fallen off somewhat, but is still high, especially compared to turnout in the USA.

One problem with this kind of analysis is that it is difficult to distinguish between the situation at a given point in time and the direction of possible trends. Many of the characteristics of present-day election campaigns – such as the nature and extent of journalistic campaign coverage in Swedish print and broadcast media – were established in the 1960s and have remained relatively stable. Other aspects have changed more, such as the parties' use of professional consultants and political marketing technicians and the personification of politics in news media.

No general Americanization

Two hypotheses have been put forward concerning American influence on the 'election campaign culture': standardization and hybridization, respectively. Standardization means that the specifically national cultures die out and are replaced by

capital-intensive campaigns that are steered by the media and consultants. Hybridization refers to a situation where national campaign cultures are complemented with features of American campaign culture, but specifically Swedish characteristics remain intact. The overall conclusion of our study is that there is no basis for talk of an Americanization of Swedish election campaigns, at least not at present. The Swedish case lends support to the hypothesis of hybridization rather than standardization. Similar conclusions have been reached regarding Danish and Norwegian campaign cultures (Jønsen & Larsen 2002, Karlsen & Narud 2004).

Americanization is a prime concern in a comprehensive study of election campaigning in many countries around the world (Plasser & Plasser 2002). Data from 43 of the countries lend support to the hybrid hypothesis. There are distinct combinations of political-cultural factors, institutions and rules that influence the form and content of political campaigns. Important among them are the election system (party-based or candidate-based), the party system (few parties or many), legislation (campaign financing, rules about advertising), and the nature of the media sector (privately owned commercial television vs public service, the press as elite vs mass medium). The USA differs fundamentally from northern and southern Europe in these respects.

As a consequence, the degree of Americanization varies between different political and media systems. Among the countries of western Europe, Great Britain, which shares a liberal media policy tradition with the USA, is the country that has adopted the most of the American model. This is especially true of political marketing techniques and the parties' market orientation. At the same time, there are major differences between the two countries; election campaigns in Great Britain focus on the parties, and British television does not carry political advertisements (Norris 2000, Blumler & Gurevitch 2001, Esser, Reinemann & Fan 2000).

The only truly transnational phenomenon is the media orientation and medialization of politics (Plasser & Plasser 2002). Television has assumed crucial importance for politics everywhere. This development has elicited different tactics to influence the media's agenda and trends in media coverage of politics, like personification. The importance of television is also reflected in politicians' willingness to submit to the logic of publicity and to open even their private lives to public view in the contest for media attention and as a means to maintain a positive 'image'. Aside from a universal preoccupation with the media, however, there are major differences in campaign culture in different parts of the world.

In a comparative perspective the American model actually constitutes an exception (Plasser & Plasser 2002). In no other part of the world do national party organizations play so little a part in getting candidates elected. Even the tenor of American political rhetoric is deviant. A comparative study of the content of political advertising in twelve countries found the USA to be the only country where negative messages predominated; in all the other eleven countries positive messages were the rule (Kaid 1999).

Professional campaign consultants, which are often described as the kingpins in North American campaign culture, are to be found in many other countries, but their role is hardly as central. Even if professional consultants are used, the strategies used in various countries continue to differ. On the one hand we have consultants who are party-driven »sales reps«, who address broad sectors of the public or the entire electorate (broadcasters), and then there are message-driven consultants who address specific demographic or lifestyle subgroups within the electorate (narrowcasters). These latter are almost exclusively an American phenomenon (Plasser & Plasser 2002).

Major variations

Comparative studies have also found that campaign culture can vary substantially between parties in the same country. Political marketing is viewed differently, depending on party tradition. Marketing technicians will not be used unless they are legitimate in the eyes of the voters, party members and the media. Criticism within party ranks is therefore an inhibiting factor. Costs are another hindrance; use of professional consultants and commissioning market studies and opinion polls are extremely costly undertakings.

The parties' use of political marketing is dependent on the resources it has at its disposal, the party's structure, prevailing views on vote maximization and the party's fundamental ideology (Gibson & Römmele 2001). Parties with money that have a top-down, hierarchical and centralized party structure, that are 'catch-all parties' and have an ideological orientation to the Right are most likely to make use of political marketing techniques. In the USA, the Republican Party used these campaign techniques long before the Democrats. In Great Britain, the Conservatives introduced the new techniques as early as the late 1970s, whereas Labour at the time were vehemently opposed. In Germany, the Christian-Democrats, CDU, used marketing as early as the election campaign of 1972 (Gibson & Römmele 2001). Later, however, both Labour and the German Social Democrats, SPD, changed their minds. Labour leader Tony Blair has come to personify the new style of political leadership, where marketing of the party's policies is prerequisite to political success. In the election of 1998, the SPD copied many of the New Labour's strategies (Esser, Reinemann & Fan 2000).

In Sweden, too, party members' views on political marketing have been mixed (Nord & Strömbäck 2003). Conservative Party members are generally accepting, whereas Social Democrats are critical. It is a matter of the image the party's voters identify with. Parties with a strong popular move-

ment tradition (the Center Party and the Social Democrats) encounter problems, as do parties whose 'image' includes a critique of commercialization (the Left and the Greens).

In practice, however, the Social Democrats have not always rejected political marketing. There have always been tensions in the party between views on how campaigns should be run and how they actually are run (Esaiasson 1990). In the early 1900s there was an ideological conflict in both the Right Party (later the Conservatives) and the Agrarian Party (later Center) concerning whether or not the parties should engage in organized 'election agitation', i.e., campaigning. In the latter half of the century, the tensions between ideology and de facto practices were most apparent among the parties to the Left. Swedish parties have shown a tendency to copy each other's initiatives in election campaigns ever since the 1800s.

Should we expect Americanization to increase? Most probably, the process of hybridization of national campaign cultures will continue. Possible changes in the structural framework (legislation and regulation of campaigns) will have an impact, as will what the media do and what struggles for media attention lead to. The development of campaign culture is, namely, intimately bound up with developments in the media and in political journalism.

'Medialization spiral'?

The general trend toward independence of journalism from the political parties is common to most countries in the West. A reservation is necessary with regard to political journalism in countries in southern Europe, where party-media ties are still quite strong.

The media generally wield more power and influence and are increasingly independent, but whether the media are stronger than parties and politicians, or vice versa, remains an open question. It is important to recognize that in Swe-

den and elsewhere, politics has changed parallel with changes in journalism. The market-orientation of journalism seems to go hand in hand with the market-orientation of politics. The interaction between politics and journalism may be visualized as a spiral, where the two institutions' reactions and counter-reactions have led to an increasingly confrontational climate between journalists and politicians. The process has been described as a »medialization spiral« (Asp & Esaiasson 1996).

When it comes to the driving forces behind the process, views differ. Some researchers blame the politicians. Journalists perceive politicians' increasingly sophisticated media strategies and techniques as a threat to journalistic autonomy. Blumler (1997) argues that journalism has changed in an attempt to retake and keep the upper hand. The rise of interpretive journalism in political journalism is similarly described as a strategy whereby journalists can take back power from the politicians. 'Smooth' campaign rhetoric and politicians' ability to catch attention have made journalists, especially those specialized in political reporting, eager to offer political analysis, where the emphasis lies on interpreting what a politician has said or done and explaining the (ulterior) motives behind the move (Blumler & Gurevitch 2001).

Others see changes in media practices to be the driving force. Politicians' skill in adapting their messages to the logic of the media, but also their success in finding ways to get around the media in order to reach out to voters directly, are natural reactions to the fact that it has become increasingly difficult to reach the voting public directly, without going through a middleman that, more often than not, will take liberties with the message. Plasser and Plasser (2002) interpret the way American campaign culture has developed as a response to a changed media environment, and particularly the logic of commercial television. It has become increasingly important for television news departments to produce news that

sells. Viewed in the long perspective, American election campaigns receive less and less media attention (Graber 2006). Campaign strategists have been forced to find new ways of reaching the voter. European politicians receive much more exposure in news and public affairs programs, which rather leads to a risk of over-exposure, of satiation. Thus, the incentive for finding new ways to reach the public is much weaker here.

Other analysts posit structural explanations of the medialization spiral and point to broader changes in society that impact on media and politics alike. Increasing individualism (tradition and socio-economic hierarchies are less important to the choices people make, and voter mobility increases), increasing social fragmentation (groups of voters become socially and culturally more heterogeneous), in combination with increasing fragmentation of the media landscape (more channels, platforms and genres compete for viewers' attention) intensify the struggle for attention and an escalation of the conflict between politicians and media.

Some researchers speak of a »crisis of democratic communication« (Blumler 1997) and a »spiral of degeneration« rather than medialization. Others, however, are skeptical of the notion of decay, of 'media malaise', the idea that journalism is in decline or that the poor quality of journalism today might pose a threat to democracy (Norris 2000). Developments in the media market over the past two decades should instead be seen as diversification: the volume of output has increased, and the number of channels by which content is distributed have proliferated. Although infotainment and tabloid journalism occupy more space, serious journalism, too, has expanded and found new channels and platforms (Norris 2000).

Many of the more pessimistic conclusions regarding a mutually reinforcing 'spiral of degeneration' are based on developments in the USA. A comparison of journalism in the USA

and Great Britain found that whereas British journalism had been popularized, the process had hardly reached the extent noted in the USA (Blumler & Gurevitch 2001).

The same conclusion may be drawn in the case of Sweden. Swedish media and Swedish politics are still in the modern phase. The logic of the market and market orientation exert only limited influence on political journalism and the conduct of politics.

The evolution of election campaigning

There are, in sum, few indications that Swedish politics has become Americanized in the last couple of decades. Medialization is reality, but the medialization of politics and market orientation has not increased to any greater degree. Swedish parties are still basically sales-, not market-oriented. International comparative research shows that the medialization of election campaigns is a universal phenomenon. The marketing orientation in politics does not have the same extent – not yet at least.

To describe changes in election campaigning in terms of modernization and professionalization is problematic in several respects. Both terms are highly value-laden. In common usage ‘professionalization’ connotes positive values like skill, knowledgeability, competence. Interviews with Swedish politicians and journalists in connection with the election campaign of 2002 found that they associated the term, ‘professionalization’ with skill in use of the chosen campaign techniques; that is to say, they associated it more with the outcome (success) of the campaign than with use of the techniques per se (Nord & Strömbäck 2003). A party may well use the entire arsenal of political marketing techniques, but so ineptly that the campaign fails. Such parties are considered unprofessional, not least by journalists.

Even the notion of modernization tends to be normative. Modernization is part of a theory that conceives of development as a more or less natural progression toward an (often implicit) goal. Different countries at different points in time are presumed to have reached different stages of an essentially linear progression. Inasmuch as American political and campaign culture is presumed to represent the norm, the highest stage of development in the progression, 'modernization' does more than signify an actual course of developments. Indirectly, it signifies a course that we should expect to take place, perhaps even advocate, in other political systems, as well. Americanization is in such cases not only a possible scenario, but something to be welcomed.

We should be cautious about drawing conclusions about the direction of change, as there is little to suggest that campaign cultures change and develop in any linear fashion. The entire underlying thesis of successive professionalization of political campaigns might therefore be called into question (Negrine & Lilleker 2002). Much of the empirical data contradicts the thesis of phases and turning points. Indeed, the record to date rather suggests a high degree of continuity in how election campaigns are run.

4. The Voters' Campaign

Jörgen Westerståhl and Bo Särilvik sent out their students to observe the political rallies held in Göteborg the last week before Election Day in 1954. Each equipped with a standardized observation form, they visited no less than 43 meetings. The results, after the data had been collated, were obviously a disappointment to the project leaders. Few of the meetings attracted very many participants; half had audiences of less than fifty. The best-attended meeting attracted 15 per cent of the district electorate (Westerståhl & Särilvik 1956:197).

At the same time, the students' observations showed that most of the meetings discussed the key issues of the election: housing, local government and taxes. The national news service, Tidningarnas Telegrambyrå (TT), sent a reporter to the larger meetings, and the wire story was duly reported in daily newspapers.

Viewed from the new millennium, the results are hardly disappointing. That as many as 43 meetings were held in the space of a week in a single Swedish city reflects a relatively high level of political activity. Also, eleven of the 43 meetings drew crowds of more than one-hundred.

Meetings that included film screenings were especially popular. The Social Democrats in Göteborg arranged three such meetings, which drew an average 172 participants (Westerståhl & Särilvik 1956). The data cannot tell us whether the main attraction was matiné idol Stig Järrel, who starred in the film, or local politics; all we know is that the meetings with screenings were exceptionally popular. The term 'infotainment' would not be coined until much later, but clearly, the combination of information and entertainment was a phenomenon even in Swedish politics of the 1950s.

Mass media were beginning to have an impact on election campaigning, but the politics of the day still had a special character. Party activists of the 1950s could still remember an era of mass political mobilization, when even more political rallies drew even larger audiences. Then, campaigns were less important; party allegiances were more stable, most voters having made up their minds even before the campaign got under way. The voters who could still be persuaded in the last weeks before Election Day were few.

The growing importance of campaigns

Election campaigning has come to play a more important role over the years. Today, whether a Government or the Opposition wins or loses is often decided in the final weeks, even in the last few days of the campaign.

Empirical research on voter behavior in Sweden shows that the number who remain undecided until late in the campaign has increased dramatically since the first measures were taken in the 1960s. In the election of 1964, only 18 per cent of the voters said they had made up their minds during the campaign: most knew how they would vote before the campaign got under way. In the election of 2002, the picture was different. A majority (57 per cent) reported making up their minds during the campaign; as many as 35 per cent said they had been undecided until the final week (Figure 4.1).

Deciding later is not the only change. A growing number of voters even switch parties in the last weeks of the campaign. The number who change their party preferences has increased from about 5 per cent in the 1950s to nearly 20 per cent in 2002.

Voter behavior in the USA has not changed as dramatically. There, too, the campaign has become more important, but not to the same extent as in Sweden. In the 1950s, roughly 10 per cent of the voters in Presidential elections said that they

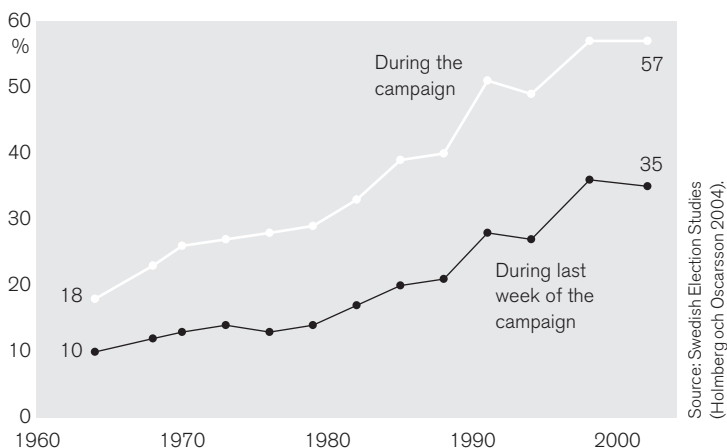

Figure 4.1 Time of voting decision

Question: »When did you decide which party you would vote for this year? Was it the last week before the election, earlier in the Fall or Summer, or have you known how you would vote a longer time?« Respondents who answered one of

the first two alternatives have been classified as having made up their minds during the campaign. Only respondents who voted for a party are included in the analysis. The number of respondents in 2002 was 2,268.

decided how they would vote during the last two weeks before Election Day or on Election Day itself. In 1964, the figure was 13 per cent. That same year in Sweden, 10 per cent of the voting public reported that they had made up their minds how to vote in elections to the Riksdag the last week before Election Day. The shares who have decided how to vote during the last two weeks before Election Day in the USA were 26 per cent in 1992, 20 per cent in 1996, 34 per cent in 2000 and 27 per cent in 2004. We should recall that there were three candidates in the 1992 and 1996 elections. In terms of the popular vote Ross Perot was a significant contender, receiving nearly 19 per cent of the vote in 1992. In the four latest Riksdag elections in Sweden, 30–35 per cent of those who voted were undecided until the last week of the campaign

(Campbell 2000, ANES 2005). Swedish voters are late to decide compared to Italian voters, as well. Comparable data from a Eurobarometer study of the elections to the European Parliament in 2004 show that only 10 per cent of Italian voters chose their party late, i.e., on or within a few days of Election Day. The corresponding figure in Sweden was much higher, 36 per cent (Eurobarometer 2004, Oscarsson & Holmberg 2006).

When it comes to switching party – lists in Sweden, candidates in the USA – in the last throes of the campaign, Swedes are again much more volatile than American voters. The share of American voters who switched parties late in the three most recent Presidential elections (with three, two and two main candidates to choose from) was 9, 10 and 6 per cent (Campbell 2000, ANES 2005). The corresponding figures among Swedish voters, who had seven parties to choose from, were 14, 18 and 19 per cent in the three latest elec-

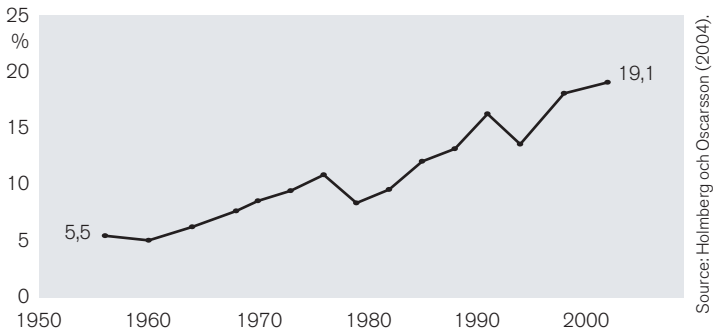

Figure 4.2 Changes of party preference during election campaigns

The figures are based on panel data from the Swedish election studies: interview data gathered before the election on »best party» and questionnaires after the election asking how the respondent actually voted. The numbers of respondents who voted and expressed party

preference before the election were 554 in 1960 and 1,145 in 1988. The number of interviewees who voted and gave information about their voting in 2002 were 817. The election study in 1970 did not include a panel study.

tions to the Riksdag (Figure 4.2). Having more alternatives to choose from naturally explains some of the difference, but the fact remains: Swedish voters are more undecided than their American counterparts, which is to say, that the final weeks of the campaign means more for the outcome of an election in Sweden than in the USA.

The unimportance of the final phase of a campaign is an established truth in American politics. 'Farley's Law' was once a well-known concept: »Most elections are won or lost before the campaign begins,« declared James Farley, veteran campaign manager for Franklin Delano Roosevelt (Campbell 2000).

The first election studies, carried out in the 1940s and 1950s, lent some support to Farley's Law. Most voters had decided how they would vote early on in the campaign, and few changed their minds during the final weeks before Election Day (Lazarsfeld, Berelson & Gaudet 1944, Campbell, Converse, Miller & Stokes 1960). Subsequent studies have noted a higher degree of electoral volatility, but no more than that American researchers still describe campaign effects as being limited and predictable (Campbell 2000).

Developments in Sweden have been more dramatic. Increasingly late decision-making and a greater frequency of switching parties have made the final phase of the campaign much more important than it was thirty and forty years ago. Leading parties and candidates can be caught up and overtaken in the very last days of the campaign. The Liberal Party's extremely successful campaign in 2002, when the party climbed from 6–7 per cent to over 13 per cent of the vote in only one month, or the skyrocketing of upstart party »the June List« (Junilistan), from 4–5 per cent to over 14 per cent in the space of three or four days in the election to the European Parliament in 2004, are cases in point. Just about anything can happen in a modern Swedish campaign, albeit most of the churn takes place within the two political blocs, not between them.

The question is: What part do mass media have in this development? Election campaigns are the largest and most central arenas in modern democracy. They offer a rendez-vous where candidates and voters meet and exchange information. The election studies conducted since the 1950s by the Department of Political Science at Göteborg University in collaboration with Statistics Sweden provide data on all three main protagonists in the election drama – voters, media, and parties.

Media exposure

The successive growth in importance of election campaigns has not been accompanied by any increase in voters' exposure to political journalism and news reporting. On the contrary. According to the election studies, the share of the voting public who read political news in the daily press has not increased since the 1960s. The share has rested at about 45 per cent who say they read most of, or at least a good part of the political information that newspapers offer (Figure 4.3). In the same span of time, however, daily newspaper reading has declined in Sweden, even if it is still very high by international comparison. The political importance of Swedish newspapers may well have declined somewhat as a result (Bergström, Wadbring & Weibull 2005).

As for television, the share of voters who at least fairly regularly watch news programs has declined slightly over the past decade. The same is true of the party leader debates on public service television (SVT), which traditionally mark the end of the campaign. The debates are the program where the largest number of voters partake of politics in the weeks and months leading up to Election Day. During the 1960s and 1970s, 70 per cent of the voters interviewed said they had watched all or part of the debates. This is a high figure, but the

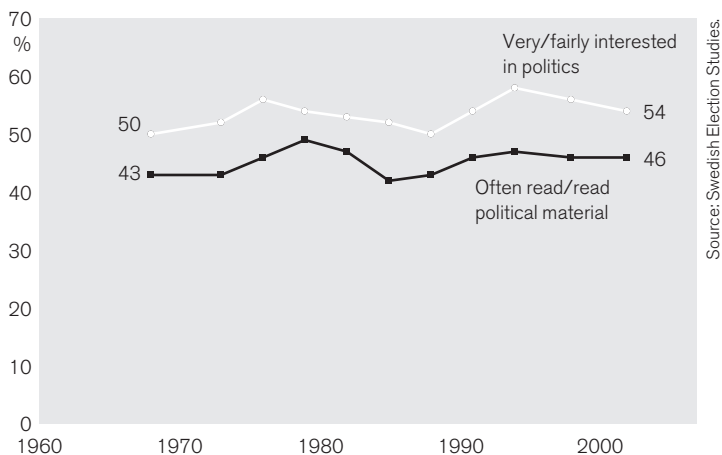

Source: Swedish Election Studies.

Figure 4.3 Interest in politics and reading about politics

The question about respondents' interest also included the responses »not very interested« and »not at all interested« in politics. The ques-

tion about newspaper reading also included the responses »sometimes read« and »never read«.

frequency has fallen off somewhat since then. In the election of 2002, 60 per cent of the voters said they had watched all or part of the program (Figure 4.4). This figure, too, sounds impressive, but it is probably an inflated estimate. According to SVT's own audience research, the actual figure was closer to 35–40 per cent (Nordström 2006). Watching the party leader debates is considered »something all good citizens do«, i.e., virtuous behavior. Therefore, when asked, people tend to say they have watched the program. Furthermore, active and politically interested people are over-represented in the Election Studies' population, which would also tend to elevate the frequency above the national average (the SVT ratings).

If the media have had any part in causing the increase in voter mobility in Sweden, it is not due to greater exposure of voters to the media. There are more media channels that carry political information, but available data suggest that vot-

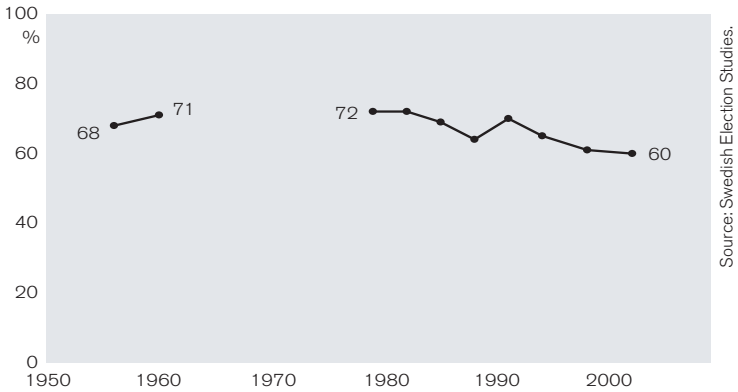

Figure 4.4 Audience of broadcast election debate

The share of the population who report listening to/watching all or part of the party leader debate which traditionally concludes the election coverage of public service radio and television (SR/SVT) in the period 1956–2002.

ers today read and watch less about politics than voters did thirty to forty years ago. The slight declines in exposure can hardly be a prime factor; if the media do indeed play a role, changes in media content are more likely to be responsible.

The importance of framing

Research in Sweden and other countries has found that a good share of the media's political reporting consists of a kind of 'horserace journalism' with a narrow focus on who wins and who loses. The issues and ideological differences between parties and candidates tend to be neglected the more media focus on individuals and crass campaign tactics. It is a phenomenon that, on the basis of framing theory, is usually called game framing or political strategy framing.

Experimental studies to identify what possible effects different framings of politics may have, have found that framing

of politics as a game can give rise to cynical mistrust of politicians on the part of media consumers (Cappella & Jamieson 1997, de Vreese 2004). Cynical and mistrustful voters have weaker allegiances and, what is more, they tend to be less knowledgeable about politics (Holmberg & Oscarsson 2004). One should be cautious about drawing conclusions about causality. It is very difficult to isolate media effects from other influences. Still, we note that in the USA three trends seem to be coinciding: increasing mistrust of politicians, greater voter mobility, and more media framing of politics as a contest or game, or as scandal.

If any causal relationship is involved, it should be accompanied by some clear-cut correlations at the individual level. For example: Extensive media exposure might be linked to mistrust of politicians, or low levels of political knowledge linked to weaker party identification and greater voter mobility. The relationships might be formulated as a hypothesis: The greater one's media exposure, the more one mistrusts politicians, the more apt one is to switch parties, and the less one knows about political issues. No such links are apparent.

The fact that the relationships at the individual level are not what the hypothesis predicts suggests that the media's effects are not the only effects at play, or that they may not even be a principal factor behind the growing mistrust of politicians and greater voter mobility. People who do consume a lot of media content are not more mistrustful, less knowledgeable, or more mobile than those who consume media rather little. The indications are rather to the contrary: high consumers are less mobile, more trusting, and more knowledgeable.

Beneath these general relationships, there are major differences between different kinds of media. In the case of morning newspapers and public service radio and television programs the links are very strong. Nor do they disappear when we control for relevant background variables like education,

age and interest in politics. As for knowledge, people with high exposure to political information in newspapers and the programs aired on public service radio and television are more knowledgeable about politics, compared to those who do not partake of these media. This holds for all education groups, all age groups and for those who are interested as well as those who are not interested in politics (Table 4.1).

Table 4.1 News habits and political knowledge.

Media habits							
<u>Read about politics in the newspaper</u>							
		Never (1)	Occas- ionally (2)	Often (3)	Daily (4)		Differ- ence (4)–(1)
	1998	13	22	53	62		+ 49
	2002	11	20	49	59		+ 48
<u>Watch/listen to newscasts on television and radio</u>							
		Never (1)	Rarely (2)	1–2 days a week (3)	3–5 days a week (4)	6–7 days a week (5)	Differ- ence (5)–(1)
SVT Rapport	1998	16	24	29	40	49	+ 33
	2002	18	22	30	34	45	+ 27
SVT Aktuellt	1998	18	24	28	42	50	+ 32
	2002	14	19	26	38	47	+ 33
SREkot	1998	23	41	56	54	51	+ 28
	2002	21	36	49	49	50	+ 29
TV4 Nyheterna	1998	43	48	40	33	34	– 9
	2002	48	45	38	33	23	– 25
TV3 Direkt	1998	42	40	30	20	18	– 24
	2002	40	37	21	15	9	– 31

The figures show the shares of respondents having good knowledge of politics. The knowledge measure is an index based on a number of knowledge questions about politics, including questions about political leaders, the political system and current issues.

Source: Swedish Election Studies. See further Holmberg & Oscarsson (2004), kap. 9.

We find strong correlations between mistrust of politicians, little knowledge of politics, and low exposure to political information in mass media. A similar link is noted for mobility (likelihood of changing party preference) late in the campaign, but not as strong. That is to say, the relationship between information exposure on the one hand, and knowledge and an attitude on the other, is stronger than that between exposure and behavior, a not uncommon finding in media effects research.

The pattern of mistrust and knowledge is mixed, however, depending on the specific medium people use. In the case of certain media, high consumption is actually linked with poor knowledge and strong mistrust. This is the case for TV4 and TV3 news programs; on average, people who watch the news on these two commercial channels are more mistrustful of politicians and less knowledgeable about politics than people who do not watch them (Table 4.2).

The relationship need not be causal; the differences are not necessarily a consequence of viewers' exposure to these channels' newscasts. The differences might instead be due to so-called 'recruitment' factors, i.e., it may be that viewers of news on these two channels have characteristics in common – here, mistrust of politicians and less knowledge of politics – that have nothing to do with their exposure to the programs. Such factors are most likely dominant.

The notion that the demonstrated link is solely a function of characteristics of the groups who watch these newscasts loses some of its force when we find that the relationships prevail even after controlling for factors like formal education, age and interest in politics. The statistical method we applied to the data is multiple regression analysis. The outcome of the analysis means that highly educated and interested viewers – and, for that matter, individuals with little formal education who are not very interested in politics – are less knowledgeable about politics and watch the news on TV3

Table 4.2 News habits and political trust.

Media habits							
<u>Read about politics in the newspaper</u>							
		Never (1)	Occas- ionally (2)	Often (3)	Daily (4)		Differ- ence (4)-(1)
	1998	17	28	37	42		+ 25
	2002	31	40	50	53		+ 22
<u>Watch/listen to newscasts on television and radio</u>							
		Never (1)	Rarely (2)	1-2 days a week (3)	3-5 days a week (4)	6-7 days a week (5)	Differ- ence (5)-(1)
SVT Rapport	1998	25	31	32	34	33	+ 8
	2002	33	40	42	48	46	+ 13
SVT Aktuellt	1998	22	27	31	32	37	+ 15
	2002	24	39	43	48	46	+ 22
SR Ekot	1998	27	34	32	35	42	+ 15
	2002	41	46	48	46	49	+ 8
TV4 Nyheterna	1998	37	31	36	30	32	- 5
	2002	40	43	44	46	45	+ 5
TV3 Direkt	1998	33	33	30	29	31	- 2
	2002	46	46	39	42	40	- 6

Share expressing trust in politicians. The figures represent respondents who say that they have »great« or »fairly much« confidence in Swedish politicians.

Source: Swedish Election Studies.

and TV4. It is indeed remarkable that exposure to these commercial channels' newscasts should show an independent relationship with low levels of knowledge about politics.

The same kind of analysis can be applied to investigate possible relationships between trust/mistrust of politicians and reading of the tabloid press. Field research data from the SOM Institute show that regular readers of Expressen (Lib-

eral and in opposition to Social Democratic governments) tend to be more mistrustful of politicians than non-readers are, i.e., the same pattern as noted for newscasts on TV3 and TV4. The results for Aftonbladet, Sweden's other nationally distributed tabloid (which supports Social Democratic governments), show an opposite relationship: regular readers of Aftonbladet have more trust in politicians than non-readers, which is the same pattern as found for newscasts on public service radio and television – and, we might add, nationally distributed morning paper, Dagens Nyheter. The SOM sur-

Table 4.3 News habits and change of party preference during the election campaign.

Media habits					
<u>Read about politics in the newspaper</u>					
	Never (1)	Occas- ionally (2)	Often (3)	Daily (4)	
	16	12	10	11	
<u>Watch/listen to newscasts on television and radio</u>					
	Never (1)	Rarely (2)	1–2 days a week (3)	3–5 days a week (4)	6–7 days a week (5)
SVT Rapport	7	11	14	11	11
SVT Aktuellt	10	13	15	10	10
SR Ekot	13	10	10	10	14
TV4 Nyheterna	8	14	10	11	11
TV3 Direkt	11	11	14	16	13

Share of respondents who changed party preference during the campaign. The figures indicate average frequencies of *party switchers* during the campaigns of 1998 och 2002.

Source: Swedish Election Studies. The figures are based on panel data, i.e. interview data gathered before the election on »best party* and questionnaires after the election asking how the respondent actually voted.

veys show that regular readers of the latter paper have more trust in politicians than non-readers do.

The correlations between media exposure and change of party preference are relatively weak (Table 4.3). Voters who never read about politics in newspapers are somewhat more inclined to change their preference, but the overall pattern is that media exposure has stronger links with knowledge and attitudes than with behavior.

Thus, the main findings are that frequent exposure to political news coverage in morning newspapers and in non-commercial broadcasting services show a positive relationship with knowledgeability and relative trust in politicians, whereas in the case of newscasts on commercial channels and the tabloid newspaper, *Expressen* (but not *Aftonbladet*), the relationship is negative – heavy consumers have poorer knowledge and greater mistrust of politicians.

These differences between media bear a correspondence to how the respective media portray politics. A study of media coverage of the election campaigns of 2002 found that of the seven media included in the study, the news program TV4 *Nyheter* and *Expressen* most frequently framed politics as a contest or game, whereas *Dagens Nyheter* and *Rapport* on SVT1 did so least (Strömbäck 2004). Users of the two media that frame politics as a contest have poorer knowledge of politics and are more mistrustful of politicians, the more they partake of the media's political news content. But the opposite obtains in the case of *Dagens Nyheter* and *Rapport*.

In sum, people who are less interested in politics tend to choose popular media, the content of which may reinforce their attitudes to politics. Their knowledge about politics and their attitude toward politicians are related to their media consumption. How the media frame politics influences people's attitudes toward politics and politicians. Mistrust of politicians finds fertile ground when politicians are portrayed as calculating, promise-breaking and vote-maximiz-

ing tacticians who exploit their position of privilege to feather their nests.

Voters' contacts with the parties

Even if we can discern certain media effects, the increasing importance of election campaigns has not been accompanied by any greater exposure to traditional media on the part of voters, rather the opposite. The same goes for traditional forms of contact within the parties. For years now, the parties have seen dwindling interest in their campaign rallies and other political meetings, few voters are contacted personally, either in their homes or at work. (Esaiasson 1990).

Some of the parties' ways of reaching out still work. Campaign pamphlets are still widely read, and no decline is apparent (Table 4.4). The share of those eligible to vote who say that they have read one or more campaign pamphlets during the campaign has been more or less constant at 55–60 per cent for many years. Revived means of contact like telephone calls reached nearly 10 per cent of the voting public in 1994 and 1998, but fell back to only 2 per cent in 2002. Six per cent of the voting public were contacted via e-mail in 1998; in the campaign of 2002 the figure had climbed to 9 per cent.

There is data enough to permit some international comparisons. For reasons mentioned in the preceding chapter, the USA, Italy and Sweden are particularly interesting countries. The comparisons that can be made between Sweden and the USA and Sweden and Italy, respectively, indicate that Swedish voters have fewer contacts with the parties or the candidates than voters in either of the other countries. Many voters in the USA and Italy report being visited in their homes or called on the telephone by candidates/parties (45 and 14 per cent, in the respective countries in 2004), compared to 2–3 per cent in Sweden in 2002). American and Italian voters also receive

Table 4.4 Voters' contacts with parties during election campaigns 1982–2002 (percentages).

	1982	1985	1988	1991	1994	1998	2002
Attended party campaign meeting	13	12	10	12	11	10	10
Visited at home by campaign worker	4	4	2	2	1	1	1
Called at home by campaign worker	–	–	–	–	7	9	2
Personal contact with campaign worker at workplace	8	7	7	6	7	5	6
Read campaign literatur	56	57	52	56	59	60	59
Visited a party's website	–	–	–	–	–	6	9

Percentages calculated on the basis of all respondents.

Source: Swedish Election Studies, post-election surveys.

more mail from the parties or candidates than Swedish voters do. Attendance at campaign rallies and political meetings seems to be about the same in all three countries, however (ANES 2005, Eurobarometer 2004).

An extensive international study, *The Comparative Study of Election Systems*, CSES, compared voter participation in election campaigns in some twenty countries, Sweden and the USA among them. The findings show that Sweden and the USA represent two poles, the Swedes having fewest contacts, and the Americans having the most. CSES data relates both to active participation in the campaign and contacts with candidates and parties. Sweden comes in last, or nearly last in both cases, whereas the USA tops the list (Table 4.5).

Only 3 per cent of voters in Sweden say they have taken active part in the campaign of 2002; this compares to 32 per cent in the USA during the elections of 2004. The differenc-

Table 4.5 Citizen involvement in election campaigns.

Country	Participated	Country	Were contacted
1. USA	31	1. Ireland	56
2. Czech republic	20	2. USA	49
3. Brazil	17	3. Brazil	47
4. Australia	16	4. Czech republic	30
5. Iceland	16	5. Australia	29
6. Mexico	13	6. Belgium	28
7. Israel	11	7. Iceland	28
8. Finland	11	8. Denmark	24
9. Hungary	10	9. New Zealand	22
10. Ireland	9	10. Finland	21
11. Denmark	8	11. Switzerland	18
12. Belgium	7	12. Mexico	18
13. Bulgaria	7	13. Korea	18
14. France	7	14. Israel	18
15. Germany	7	15. Norway	15
16. New Zealand	7	16. Portugal	15
17. Norway	7	17. Germany	13
18. Portugal	7	18. Bulgaria	8
19. Switzerland	7	19. Hungary	8
20. Taiwan	7	20. France	7
21. Spain	6	21. Sweden	7
22. Korea	4	22. Spain	6
23. Poland	4	23. Poland	5
24. Sweden	3		
Average 24 countries	10	Average 23 countries	21

Participated: »Here is a list of things some people do during elections. Which if any did you do during the most recent election? Did you show your support for a particular party or candidate by, for example, attending a meeting, putting up a poster, or in some other way?«

Were contacted: »During the last campaign did a candidate or anyone from a political party contact you to persuade you to vote for them?«

Source: The Comparative Study of Electoral Systems (CSES). Data collected during 2002–2004. Percentage base: all respondents.

es are equally large when it comes to being contacted by the parties or candidates: in the USA 49 per cent report having been contacted, in Sweden only 7 per cent.

If we broaden our perspective to include indirect contacts

with the parties and candidates via the media, the picture for Sweden's part brightens somewhat – in comparison with Italy, at least. The Eurobarometer survey taken in conjunction with the elections to the European Parliament in 2004 show that Swedes came in contact with campaign in the form of newspaper articles and advertisements, via radio and television and the Internet more than their Italian counterparts. The difference was not great; in most cases a margin of 2–10 percentage points. Only in the case of newspapers does Sweden come out significantly higher than Italy, with 81 per cent, compared to 57 per cent, which mirrors the penetration of newspapers in the two countries.

A lack of comparable data makes it impossible to compare Swedish and American voters. American election researchers' observations from the Presidential campaign in 2004 do not indicate that media exposure to the parties and candidates via the media should be any greater there than in Sweden. Possibly via monthly and weekly magazines, but definitely not via broadcast media. Exposure to political information via newspapers was not measured in the American study. In 2004, 86 per cent reported having seen at least one election program on television, 30 per cent said they had read an article in a magazine, and 52 per cent said they had listened to one or more speeches or debates on the radio (ANES 2005).

One may hope that direct contacts between the voter and the parties have positive effects, not negative, on attitudes toward politicians and voters' knowledgeability about politics. It would definitely be disturbing if people lost confidence in politicians or became less knowledgeable as a result of first-hand contact with the parties during a campaign. If media contacts do not always strengthen people's trust in politicians and result in better knowledge of politics and political processes, then we might at least venture the thesis that direct contacts have positive effects. Earlier studies of variations

in public trust in/mistrust of politicians and degree of identification with one or another party have found increases in both in election years. Trust in politicians and party loyalties are stronger in election years than in the intervals between elections (Holmberg & Weibull 2005, Strömbäck & Johansson 2006). When elections come around, and the candidates make an effort to meet the people, trust and confidence rise.

The findings shown in Table 4.6 confirm this observation. Voters who reported having had some form of direct contact with a party tend to have greater trust in politicians and know more about politics. The correlations between knowledge and all forms of contact, except for visits in the home and telephone calls, are positive. A characteristic of the group of voters who have been in touch with one or another party during the campaign is that they know more about politics and are more trusting of politicians.

But what is cause, and what is effect? The correlation data in Table 4.5 are maximum estimates. Possible effects can be no greater, but most likely are somewhat or decidedly less. The data are also cross-sectional, they describe a single point

Table 4.6 Effects of campaign exposure: maximal estimates.

	Political know- ledge: increase/ decrease	Political trust: increase/ decrease
Attended party campaign meeting	+ 14	+ 9
Visited or called at home by campaign worker	- 4	+ 15
Contact with campaign worker at workplace	+ 5	+ 3
Read campaign literature	+ 7	+ 12
Visited a party's website	+ 10	+ 17

The percentage differences show increase/decrease in high political knowledge and high political trust among those who were exposed to various contacts with parties' campaigns, compared to the corresponding frequencies among those who have not had such contacts.

Source: Swedish Election Study 2002.

in time. The differences in knowledge and trust noted need not be a consequence of contact versus lack of contact with the parties. They may be due to selection, i.e., knowledgeable and trustful voters are more likely to be open to contact with the parties than other voters are. The data we have at our disposal does not permit us to say which factor is at play here. We can only say that the observed relationships fit our hypothesis and that they are most likely slightly overstated.

Knowledge improves, but only slightly

In modern election campaigns we find that voters tend to make up their minds closer and closer to Election Day. A growing number also switch parties during the final weeks of the campaign. The question – equally important and difficult to answer – is: Are the two phenomena exclusively a consequence of the campaigns? Other factors – such as generally less respect for authority, all too similar party programs, and increasing social mobility – may play in.

It would hardly be surprising if the campaigns were found to have influenced the voters. The whole idea of a campaign, after all, is to do just that. Voters should be given an opportunity to orient themselves as to what the parties stand for and intend to do, and to assess what they have achieved during the past term of office. Campaigns also afford voters an opportunity to tell the parties what they want. The communication flows two ways.

In a party-based representative democracy campaigns should, at a minimum, have a vitalizing effect when it comes to the citizen's political knowledge, interest and trust. Voters' knowledge should increase, not decrease. The same goes for their interest in politics; it should increase as a consequence of a campaign. Trust in politicians and one's identification with one or another party should also be strengthened when

voters have an opportunity to meet their elected representatives in the course of the campaign.

The findings of studies of changes in voters' knowledge and interest during campaigns leading up to national referenda have not been entirely positive. (Certain characteristics of referenda in Sweden should be borne in mind: The issues involved do not necessarily follow partisan lines. Indeed, as an instrument they tend to be used when the party-based parliamentary system does not adequately reflect public opinion. Secondly, the outcomes of Swedish referenda are advisory, not binding.)

In the referendum on nuclear energy in 1980, for example, voters did become more knowledgeable, but at the same time interest and enthusiasm flagged a bit. There was too much redundancy; the same issues were brought up again and again. The campaign was too long (Holmberg & Asp 1984, Asp 1986). The effects were more uniformly positive in the campaign leading up to the 1994 referendum on joining the European Union (Gilljam & Holmberg 1996). Both knowledge and interest increased. In the case of the referendum on the Euro (more precisely: Swedish adhesion to the European Monetary Union) in 2003, the effect on knowledge was less apparent (Oscarsson & Holmberg 2004).

Table 4.7 summarizes the effects noted in conjunction with Swedish election campaigns. The figures represent the differences between interview responses before and after Election Day. A plus or minus sign indicates the direction of change in voters' knowledge and trust in relation to the measures taken before the election. The figures are averages of data for the six Swedish elections between 1985 and 2002.

The differences noted are not necessarily effects of the campaigns. We lack panel data, where the same respondents are interviewed twice. Instead, the pre- and post-election measures were taken from different samples of voters. Random variation may explain some of the differences between

Table 4.7 Effects of campaigns in six elections 1985–2002:
percent increase/decrease.

	Interest: increase/ decrease	Party ident- ification: increase/ decrease	Trust: increase/ decrease	Know- ledge increase/ decrease
All	+ 1,0	+ 0,2	+ 0,8	+ 0,8
Women	0,0	- 0,8	+ 2,6	+ 1,3
Men	+ 2,0	+ 1,2	+ 0,4	+ 0,2
18–21 yrs	+ 5,2	+ 1,5	+ 4,6	+ 0,3
22–60 yrs	+ 0,2	- 0,8	+ 1,4	+ 0,3
61–80 yrs	- 1,3	+ 1,8	- 1,4	+ 1,8
Education: low	- 2,7	- 0,5	- 2,0	+ 0,5
Education: medium	+ 4,2	+ 0,5	+ 1,2	+ 1,2
Education: high	+ 2,3	+ 0,2	+ 5,0	0,0
Left	+ 5,0	- 1,3	- 0,2	+ 2,3
Social Democrats	- 0,7	+ 0,8	- 0,8	- 0,2
Greens	+ 1,3	- 6,3	+ 1,8	- 1,5
Center	+ 3,2	+ 4,2	- 2,8	0,0
Liberal	- 0,7	- 8,0	- 3,0	+ 0,5
Christian Democrat	- 9,7	0,0	- 5,6	+ 4,0
Moderate	+ 3,7	0,0	+ 5,8	+ 0,5
No preference	+ 3,8	-	0,0	- 0,2
Read about politics in newspapers				
Never	+ 4,3	+ 11,0	- 1,5	- 0,5
Occasionally	+ 2,8	+ 0,5	+ 2,3	+ 0,3
Often	+ 2,0	- 0,3	+ 3,0	- 0,8
Daily	+ 1,5	- 3,3	- 0,5	+ 1,3
Watch Rapport (public service TV news)				
Never	0,0	- 5,5	- 2,0	- 1,3
Rarely	+ 5,3	+ 2,7	+ 4,0	- 1,5
1–2 days/week	+ 3,5	+ 0,5	+ 5,2	- 0,3
3–5 days/week	+ 1,0	+ 0,7	- 0,2	+ 1,0
6–7 days/week	+ 0,3	- 1,3	+ 2,0	+ 1,5

Interest: Difference in share who respond »very interested« and »fairly interested« in politics.

Party identification: Difference in shares who identify with a political party.

Trust: Difference in share who express great confidence in politicians.

Knowledge: Difference in share who score high on index of political knowledge (cf. table 4.1).

Source: Comparison between pre-election and post-election surveys, Swedish Election Studies. Results for newspaper reading cover four elections (1991–2002); other results six elections (1985–2002).

the measures. The post-election debate and some beginning memory loss may also play in. Many of the interviews were conducted several weeks after Election Day.

First of all, we find positive results on all four measures. Swedish campaigns for elections to the Riksdag increase voters' political interest, degree of party identification, trust in politicians and political knowledge. So far, so good. But the findings are not totally clear-cut; there are some shadows of doubt. All four measures are only slightly positive, ranging from +0.2 to +1.0 percentage points. Moreover, since the figures are averages, they may well mask negative effects in one or more campaigns. The positive effect, in other words, is not very strong. The main conclusion is that Swedish election campaigns have positive, albeit only very slight, effects on voters' knowledge of politics and trust in politicians.

Our data permit an analysis of possible differences between demographic and political groups. Men and women are influenced equally, but there is a strong differential with regard to age. The effects on younger voters are clearly more positive with regard to interest and trust than among older groups. As for education, highly educated groups show the most positive change, particularly in their trust of politicians; respondents with little formal education show a less pronounced effect, and often a negative one in the case of interest and trust. That is to say, the campaigns tend to dampen interest and trust among those with little formal education. That campaigns should reinforce, even widen, gaps between education groups is cause for concern.

We note major differences among groups defined by their party preferences. Among those attracted to the Liberal and Christian-Democratic parties the changes noted are mostly negative, with less trust in politicians and less interest in politics in the post-election measures. Among Conservatives, by contrast, the changes tend to be positive. We should be careful about drawing any far-reaching conclusions, however.

The method used does not take account of changes of party preference that may have occurred in the final weeks of the campaign; the composition of groups preferring the respective parties may differ between the pre- and post-election measures.

Turning to media habits, we find an interesting pattern. Among heavy consumers of political information in newspapers we find a positive effect with regard to knowledge and interest. The group knows more and expresses greater interest after the election than before. But, when it comes to trust in politicians, the effect is negative. In the case of public service television, regular viewers of SVT1's news program, Rapport, show the same pattern when it comes to knowledge, but are also less sure about their party preferences. Their trust in politicians has not diminished; on the contrary, it shows an increase.

A special analysis of commercial channel TV4's news program in the elections of 1994, 1998 and 2002 reveals a pattern that only partly resembles the pattern for regular viewers of Rapport on SVT. In the case of TV4 we find no positive effects – neither on knowledge and interest in politics as for other media, nor on trust in politicians or degree of party identification. In the latter case, viewers of TV4 show the same pattern as readers of newspapers. Election coverage tends to increase mistrust of politicians and dampen enthusiasm for the parties.

All in all, the findings mean that mass media, represented here by newspapers and Rapport, reinforce the motivational and knowledge elements in democracy, but undermine voters' trust – chiefly in the parties, but also in politicians to some extent. Whether this is good or bad is hard to say. If we presume that politicians deserve criticism, that they have not lived up to the trust invested in them, then the results might be positive. On the other hand, if the parties and politicians are already unfairly disdained, the results might be negative.

What voters do and think

Any evaluation of Swedish election campaigns will necessarily end up with a mixed result. Overall, the effects are essentially positive, but not very strong. The positive effects noted have in fact been very weak.

The media's performance has also been rather mixed. A knowledge increment is coupled with a negative effect on party identification and trust in politicians. Party-based representative democracy does not receive wholly positive support from media coverage.

The picture is equally mixed when we consider the parties' direct contacts with voters. Many older, established forms of communication are little used these days, and new means of communication have emerged. But, all in all, the parties' interface with the voting public has not diminished. For the sake of the vitality of representative democracy this, of course, is positive, especially if the effects of most of the forms of contact are positive: knowledge increases, trust grows stronger, and interest is aroused.

The final question is what the voters themselves do and think. Some voters are active opinion leaders during the campaigns. In election studies since 1985, the post-election interviews have included a question about whether the respondent has tried to persuade family and friends or others to vote for a certain party. The question is inspired by Lazarsfeld's hypothesis of a two-step flow of communication with a focus on the vital role of opinion leaders (Lazarsfeld, Berelson & Gaudet 1944). Our measure asks specifically about attempts to influence others' voting behavior, not opinion formation more generally.

The share of partisan 'opinion leaders' (according to the above definition) among the Swedish voting public has consistently rested at about 15 per cent. This is a healthy sign for a party-based democracy. Whereas other indicators – e.g.,

party membership and degree of party identification – have shown a downward trend, no decline is noted with respect to voters' attempts to influence other voters.

Whether 15 per cent is many or few depends on one's frame of reference. Compared to the corresponding frequency in the USA, it is definitely low. There, as many as 49 per cent said they had tried to persuade somebody to vote for one or another party or candidate during the campaign of 2004 (ANES 2005). The Comparative Study of Electoral Systems (CSES) material for the period 2002–2004 points in the same direction. As noted above, Sweden ranks low when it comes to the degree of voter participation in election campaigns, particularly compared to American voters. Of the 23 countries surveyed in the CSES study, Sweden ranks seventeenth, with 13 per cent opinion leaders. The USA tops the list with 44 per cent.

As Table 4.8 indicates, opinion leaders have many of the characteristics one would expect to find. They are more knowledgeable than average, more interested in politics, and more active in their information-seeking behavior in newspapers and on the web. As for television viewing, they are no more active than other voters.

Opinion leaders in the sense we use the term here are as likely to be women as men. They are more common among younger voters than elder groups, which is worthy of note when we consider the 'greying of the parties' on the whole.

Opinion leaders are more common among the well-educated. They are to be found among all parties, but especially among those voting for the Left Party and the Greens. The Liberals, Social Democrats and the Center Party have fewer opinion leaders among their ranks than the average. It is remarkable that among party members (all parties) the frequency of opinion leaders is no more than 30 per cent; that is, more than two party members in three have made no effort to influence anyone else's vote. Party members are not only a dwindling species, they are also relatively passive.

Table 4.8 Opinion leaders (average, elections 1985–2002).

Percentage opinion leaders		Percentage opinion leaders	
All	14,2	All	14,2
Women	13,8	Member of party	
Men	14,5	Yes	29,7
		No	12,3
18–30 yrs	18,8	Political trust	
31–60 yrs	13,8	Very great	31,0
61–80 yrs	10,5	Fairly great	17,4
Education: low	9,8	Rather little	11,4
Education: medium	13,5	Very little	11,2
Education: high	21,0	Reads about politics in newspapers	
Riksdag vote		Reads all there is	22,5
Left	23,8	Often	18,5
Social Democrats	13,7	Occasionally	11,0
Greens	23,3	Never	6,0
Center	11,0	Watch SVT Rapport	
Liberal	11,7	6–7 days/week	13,0
Christian Democrats	17,5	3–5 days/week	15,0
Moderate	16,7	1–2 days/week	14,8
Did not vote	6,7	Not very often	15,2
Interest in politics		Never	10,8
Great	35,5	Watch TV4 Nyheterna	
Fairly great	16,0	6–7 days/week	15,3
Not very much	8,0	3–5 days/week	17,8
Not at all	5,8	1–2 days/week	13,3
Party identification		Not very often	16,3
Strong	25,0	Never	15,3
Weak	14,8	Visited party's website	
Preference only	10,7	Yes	39,0
None	4,5	No	12,5
Political knowledge		Visited MP's website	
Very good	22,0	Yes	36,0
Good	17,8	No	13,0
Average	13,3		
Poor	11,3		
Very poor	8,8		

Question: »Before the election, did you try to influence anyone among family, friends and acquaintances to vote for a certain party?« Most of the analyses include six elections, 1985–2002. Results for political trust are based on five elections (1988–2002); for newspaper reading and viewing of TV4 Nyheterna four elections (1991–2002), and web activity two elections (1998–2002). The results for All over the years have been: 1985 15 %, 1988 11 %, 1991 15 %, 1994 15 %, 1998 14 % och 2002 15 %.

Source: Swedish Election Studies, post-election surveys.

The election studies since 1985 have also given respondents an opportunity to rate the campaigns and the most important actors, i.e., parties, party leaders and media. The results (Table 4.9) are not very encouraging; the views expressed are very critical. On closer inspection, however, we find a ray of hope: voters are less critical today than voters were in the 1980s.

The assessments of Swedish election campaigns that unite most respondents in these studies criticize partisan quibbling (about 60 per cent by and large; in 2002, only 46 per cent), and an excessive focus in campaigns on party leaders (about 40 per cent). In earlier measures, voters expressed the view that the campaigns were characterized by too much conflict and aggression, but no longer. Whereas 36 per cent expressed this view in 1985, only 9 per cent did so in 2002.

Table 4.9 Voter opinions about election campaigns.

	Percentage agree					
	1985	1988	1991	1994	1998	2002
The election campaign...						
... contained too much of bickering	66	66	51	61	62	46
... was too focused on the party leaders	39	27	36	31	40	38
... was interesting and exciting	13	10	22	18	9	19
... was too conflictual and aggressive	36	26	13	16	13	9
... election debate in media was too complicated	15	18	13	15	17	16
... showed clear differences between parties	13	18	14	14	12	14
... was factual and informative	3	3	6	5	2	5

Results are based on post-election mail survey. Respondents were also part of the pre-election survey.

Source: Swedish Election Studies.

That as few as 15 per cent of the respondents (throughout the period) feel that the campaigns have clarified the differences between the parties must mean that voters do not feel they have clear-cut alternatives to choose from, which is a shortcoming in the campaigns. The same is true of the fact that only 5 and 15 per cent, respectively, rate the campaigns as factual/informative and interesting/exciting.

Media performance is also covered in the interviews. Here, the media get rather good ratings. In all the years the surveys have been taken only about 15 per cent of the voters, one in seven, say that press and radio and television accounts of the election debates have been difficult to understand. Few voters voice complaints about media coverage – at least when it comes to comprehensibility.

The greatest amount of criticism regarding comprehensibility is noted among viewers of TV3 and TV4. Least criticism is noted among high consumers of political news in newspapers, closely followed by public service television and radio. Thus, here, too, the commercial channels' performance leaves something to be desired.

What is need not always be

This chapter may be summarized in a number of general tendencies. Voters find it increasingly difficult to decide which party they have most confidence in and will vote for. They have become more fickle, less faithful and are increasingly prone to switch party allegiances.

Increased voter mobility does not mean that Swedish voters are particularly active or enthusiastic. Compared with voters in some twenty other countries, they are among the least active in election campaigns.

The parties are partly to blame. Several of the traditional channels of communication – party rallies, house calls, etc. –

have lost their vigor, and new ones – principally web-based solutions – have only just been launched, and cautiously at that. At the same time it should be pointed out that when the parties reach out, the effect is generally positive with regard to voters' knowledge and trust.

Nor are the media entirely blameless. Some traditional mass media have lost their audiences during election campaigns, and the remaining voters are not necessarily moved positively by what they read, hear and see. Some commercial media actually have a negative impact – voters who partake of them lose some of their motivation and political knowledge.

All in all, these tendencies mean that election campaigns – the most important and all-inclusive democratic fora – have only weak, but limited positive effects on such central democratic values as political knowledge and citizens' involvement. We can take some comfort in that the effects are positive; they might have been negative.

What is need not always be. Swedish election campaigns should, and can, be revitalized so that they function much better than is the case today. That goes for the parties, media – and voters, too.

5. Internet: A new Town Square?

Starting each chapter with a reference to the report, »Swedish Election Campaigns« (Svensk valrörelse) from 1956 was a way to cast our present findings in perspective. Rereading that classic study gives us cause to reflect over how scientific analyses age. Not even the most ardent striver for objectivity can free him- or herself from the *Zeitgeist*, from the dominant paradigms and frames of reference of the time.

In the mid-1950s, one could see that mass media, especially radio, were beginning to have an impact on election campaigning, but party rallies, the party press and monopoly radio were still the dominant frame of reference. Only a few years later the situation would change dramatically.

Until 1956, public service radio interpreted its duty to observe impartiality very strictly; 'balance' was of the essence. If one side in a controversy declined to comment on an issue, broadcast journalists could not bring it up. In 1958, television started regularly scheduled newscasts, but with very little political coverage. The election of 1960 came to be known as »the first TV election«. Another two years later, when television became available throughout the country, the medium was said to have turned the whole of Sweden into one big town meeting. As we have pointed out in previous chapters, the emphasis in journalism began to turn from mirroring reality to actively and critically scrutinizing it.

The question is whether our report has the same »timing« and retrospective slant as Westerståhl's and Särilvik's work fifty years ago. Here we describe the power constellations and processes that have characterized election campaigns these

past few decades. At the same time, the authors sense that the present they are describing will soon be history. There is much that indicates a very rapid transformation of the media sector that will have profound repercussions on the most central feature of representative democracy, viz., the meeting of voter and candidate. Fifty years ago observers wondered if television would be the new meeting hall; today we can ask ourselves the same question about Internet and the new information and communications technologies (ICT). Do they have the potential to offer a new meeting place, a new Town Square?

The first Internet election

Ever since the mid-1990s the question has been when the first real »Internet election« will be. Even if the speculations are often exaggerated, most observers are of the opinion that sooner or later »the web« will change the dynamics of political communication. The Presidential election of 2004 in the USA is generally considered the first election where Internet played a prominent role (Ceaser & Busch 2005, Williams 2005).

Two main features of the web are perceived to pose challenges to traditional news journalism. The first is that the web allows political campaigners to communicate directly with the voter without going by way of traditional media and the journalistic filter they represent. Politicians can talk to and »chat« with the people, at least with those who look for political information on the web.

The second factor is that the web makes it possible for practically anyone with a rudimentary mastery of computers and a little money to make their voices heard. Where the media were once the only way to influence the current of public debate, Internet in general – and blogs in particular – have

opened up entirely new opportunities (Våge, Stattin & Nygren 2005, Wiese & Gronbeck 2004, Williams 2005).

If we look back ten years or so, a lot has already changed. The public sphere has grown; new actors have entered and now challenge news media's institutionalized monopoly on the public arena. Blogs that are critical of the media affect news media more directly through their critical vigilance. It is also easier for ordinary citizens to contact journalists directly, by sending e-mail, commenting on websites or organizing e-campaigns. If journalists of yesteryear could only guess what people were thinking, now they know, both quicker and more often.

Thus, the web and ICT have expanded and extended the public sphere. Paradoxically, at the same time the public sphere has also become partitioned. Whereas traditional media address the public at large and try to offer »something for everyone«, many web media and blogs address sectors of the public, generally institutionally affiliated and essentially like-minded groups. Before Internet, the average American who followed domestic politics could not avoid being exposed to the views of both Republicans and Democrats, but with Internet it is entirely possible to partake of only one party's argumentation, as in the days of the party press. The situation is not quite as extreme in Sweden as yet; niche media and blogs are not as many here, but the trend runs in the same direction. The 'party press' may well be resurrected on the web.

Alternative and new public spheres

Critics of traditional media and politics often express the hope that new media and modes of communication will fill the democratic vacuum. New media might, for example, change the conditions under which political campaigns operate.

There is, however, a tendency to exaggerate the novelty of »new media«. Most of what we call »new Media« is not actually new, but rather old and familiar, but recombined on new platforms. The Internet is not a »medium«, »system«, or »channel«, it is a platform on which different technologies and genres are mixed.

The novelty of the web is its capacity for interactivity. Two-way communication makes it possible for users to become co-creators. The distinction between producer and consumer blurs. The web also makes it possible to transcend both space and time. Instant communication became possible with broadcasting; the web represents a radical step further. The technology has an immense democratic potential, but the question is whether 'cyber-democracy' works in practice.

Election researchers, too, see both strengths and weaknesses in the new media with respect to how they function in democratic processes. An international survey of campaign cultures made in the late 1990s found that the web had not become a significant campaign medium in any of the countries studied (Plasser & Plasser 2002). Television, whether privately or publicly owned, commercial or non-commercial, was totally dominant, except in some parts of Africa and Latin America where radio reached more people. The only countries in the study where the web had any significance in campaigns were Taiwan and Japan. At the time of the study, however, many observers – American consultants in particular – were convinced that it was only a matter of time before Internet assumed a major role.

Democracy in »the blogosphere«

Discussions of new media in election campaigns often revolve around 'the blogosphere'. A blog – a contraction of the term, 'weblogs' – is a kind of regularly updated web diary with links to other blogs and sources (Våge 2005).

Most blogs are neither political nor interested in public affairs. An inventory of the Swedish blogosphere in early 2003 found rather few active bloggers in Sweden (less than 300); only 10 per cent of the blogs were interested in social issues or public affairs (Isaksson & Müller 2003). In 2005, the number of active bloggers had grown to 800 (Observer 2005).

The blogs that are interested in public affairs and social issues vary quite a lot as to both form and content. Some consist of notices with numerous external links; they neither explain their purpose nor express any views (Isaksson & Müller 2003). Others offer reasoned essays or carry on debates with others. One important feature of the socially oriented blogs is that they direct traffic toward other debate fora than those generally covered in traditional media like the press, radio or television.

In the USA, the web and blogs have been widely discussed in connection with the Presidential election of 2004 (Peterson, Holmberg, Laurin & Strömbäck 2005). The Democratic candidate Howard Dean demonstrated that Internet can be used to mobilize supporters quickly, to raise funds, and to test proposals on various policy issues directly on one's following. Mr Dean did not manage to get his party's nomination, but his campaign is generally remembered as both successful and innovative.

Blogs had decisive effects for the respective candidates, George W Bush and John Kerry, but in very different ways. In Bush's case, blogs saved the day. Bush was harshly criticized on 60 Minutes, CBS Television's prestigious program of investigative reporting and news analysis, for flagrant absenteeism when he did his military duty in the Texas National Guard back in the 1960s. »www.freerepublic.com«, a pro-Bush blog, questioned the authenticity of the documents the 60 Minutes team had relied on, and the criticism gathered such momentum that it put a premature end to the otherwise illustrious career of the network's veteran reporter and news

anchor, Dan Rather. Blogs, on the other hand, hurt John Kerry's campaign. One of the main points in the Kerry campaign was the candidate's decorated service as a soldier in Vietnam. Information suggesting that Kerry's military record was not as heroic as his campaign alleged was widely spread via blogs to traditional news media.

Of course, to be effective blogs need to reach an audience, but the record to date in the USA indicates that they are indeed a factor to be reckoned with. Networks of bloggers have managed to bring down leading politicians and journalists by continuing to discuss issues that established media initially left untouched.

Blogs' latent importance has brought increasing numbers of journalists to include at least some blogs as possible news sources; as a consequence, blogs have acquired some influence over media agendas. We should be cautious about exaggerating their influence, however. Traditional media are still far more influential, and it is only when they reinforce what has been written in a blog, that the blog can exert any greater influence.

In Sweden the discussion of blogs and their importance got under way in 2005, which may be considered the year blogs made their debut in serious public debate. Bloggers and users of blogs in Sweden are an assortment of independent debaters, MP's, political party staff, and academic researchers. There are now blogging MP's in all the parties (Stattin 2005). Clearly, blogs can serve any number of functions in an election campaign, but ideas about their potential consequences are largely speculation as yet (Observer 2005).

Shadow campaigns and alternative media arenas
Politics and politicians inhabit other genres besides traditional news and election programming. Popular culture media, too, convey images of politics and politicians to their read-

ers and viewers, images that the latter may choose to discard, absorb or negotiate. Thus, election campaigns are also under the influence of popular culture depictions, as well.

Media output has mushroomed, and new entertainment and fictional programs contain facts and stimulate debate (Carpini & Williams 2001). Fragmentation and genre-mixing are in themselves factors that undermine both the parties' and the established media's hegemony with respect to who sets the agenda. The scandal surrounding ex-President Bill Clinton's escapades with Monica Lewinsky is an example of how a mixture of genres and platforms for distributing news have made it difficult for traditional gate-keepers to control information flows (Carpini & Williams 2001). Sweden is no exception. Programs of satire and humor and other expressions of popular culture challenge traditional images of politicians and other wielders of power (Edström 2006).

Politicians appear increasingly often in genres like morning talk-shows and studio entertainment. Many media researchers are highly ambivalent about the interaction between politics and popular culture. On the one hand, they criticize the superficiality of popular media's image of politics and its oversimplifications, verging on populism. Still, there is the possibility that, by inviting marginalized groups to discuss subjects that are not normally included on traditional political agendas, tabloid newspapers and other popular culture media may actually help to expand the public sphere (Dahlgren & Sparks 1992, McNair 2000, Jönsson & Örnebring 2004).

Media researcher Mats Ekström is critical. In an article about television viewers and democracy, he shows that the chat culture on Internet does not necessarily promote democratic ideals (Ekström 1999). Ekström analyzed lists and chat pages having to do with Aschberg & Co., a weekly Swedish talk show aired on the entertainment-oriented satellite channel, TV3 in the 1990s that was known for its cavalier and pro-

vocative manner of discussing current issues. The program was critical, but also entertaining. The chat pages were playful in their treatment of established genres and styles of dialogue, freely mixing jokes, sarcasm and serious reflection, but where facetious humor often degenerated into scornful mockery and the program's critical attitude increasingly expressed cynical contempt of everything and everyone associated with the Establishment, including politicians or journalistic conventions. Ekström concludes that whereas skepticism of politics and authority can be healthy and beneficial to democracy, when »mistrust turns into cynical scorn, populism and antidemocratic values, it becomes a problem for democracy,« instead (Ekström 1999:192).

Aschberg & Co. may be seen as an example of the tabloidization of political journalism, but also as an example of how popular culture has become involved in public discussion of politics. Political scientists tend to be critical of medialization and popularized political journalism. Some hold, however, that 'tabloidization' is a problem only under three conditions: when it is the dominant form of political journalism; when politicians take to popular media genres to avoid critical scrutiny on the part of traditional political journalists; and when tabloidization contributes to spreading distorted ideas of politics (Brants 1998). None of this characterizes the European media context. The mixture of political information and entertainment in many popular journalistic genres may instead once again make politics »popular« – in more than one sense of the word (Brants 1998).

Meanwhile, there are indications that popular culture is gradually becoming politicized (Jones 2005). In the American Presidential election of 2004, the campaigns were carried out in popular culture genres alongside the candidates' official campaigns. These 'shadow campaigns' involve activists and celebrities, but established political insiders, as well. Even some journalists take part. They inject politics into films, mu-

sic, radio, books, television and the web. The information relates to, but is not necessarily the same as the political debate in national media. The 'shadow campaign' raises critical points and issues that do not make established media's agendas.

'Shadow campaigns' may have many different features: In the USA, Michael Moore's documentaries, search engines on Internet, social criticism embedded in cartoon series like South Park and The Simpsons, and the concert tour, »Vote for Change« with superstar Bruce Springsteen, the express purpose of which was to get out the anti-Bush vote, are but a few internationally known examples. Thus, popular culture offers critical voices and individuals outside established political and media circles a podium.

Political rallies of new kinds

The conditions under which politics is conducted and media operate are also a function of technological and socio-cultural changes. Developments to date have meant an overall fragmentation of politics, the public and journalism. Fragmentation in itself leads to increased competition for attention, which in turn elicits responses like political marketing and commercialization of news values.

The implications of new communications technologies for the media and politics have been discussed extensively these past few years, both in society at large and within the research community. The technologies are believed essentially to reinforce prevailing national campaign cultures, while blogs and the parties' activities on the web (intranets and home pages, etc.) may actually change how campaigning is done.

Thus, Internet has a potential to assume more important roles in election campaigns of the future. Increasing politicization of popular culture is another change that is expanding the bounds of political debate, both as regards participants and content.

No straight-line course of development is apparent, however. Post-modern election campaigns in combination with e-media may represent a return to the direct contacts between voters and their elected representatives that characterized politics years ago (Norris 2000). Intranets, political discussion groups, e-mail lists, e-newsletters and interactive news sites offer parties the option of organizing virtual caucuses, platform conventions and campaign rallies. Nationally televised election campaigns, which are largely a form of spectator sport, may in that case one day be regarded as a historical parenthesis.

Internet and democracy

Sweden has one of the highest rates of Internet penetration in the world. So far, Internet is chiefly used for e-mail, but other uses, like e-shopping, e-banking and interaction with the public sector, are increasing (Bergström 2004, 2006). The question is, what role may the web assume for citizens in their role as voters.

Voters' use of Internet

People who contact the parties or gather information about them via Internet are more knowledgeable and have greater trust in politicians than other voters. As noted in the preceding chapter, web-mediated contacts with political parties are most common among voters registering high trust in politicians and above-average knowledge of politics.

Table 5.1 offers more detailed information about the voters who take such contacts with parties and members of the Riksdag. The pattern is fairly clear. Most contacts are taken by young, well-educated men – a familiar pattern from studies of uses of Internet in other areas than politics (Berg-

ström 2004). If we look to users' party preferences, Liberal and Conservative sympathizers take the most web-mediated contacts with their parties, and those stating a preference for the Center Party or the Social Democrats do so least.

The voters that parties and MPs reach via the web are comparatively well-versed in politics, have a stronger-than-average party identification, are more interested in politics and have more trust in politicians. Thus, Internet as channel of political communication shows essentially the same pattern

Table 5.1 Who uses the Internet to find information about parties and MPs?

		Visited a party's website before election	Visited an MP's website in recent years
All	1998	8	6
	2002	9	7
Women	1998	6	4
	2002	7	6
Men	1998	9	7
	2002	10	8
18–22 yrs	1998	17	11
	2002	18	12
22–60 yrs	1998	5	4
	2002	8	7
61–80 yrs	1998	3	3
	2002	1	2
Education: low	1998	1	1
	2002	1	2
Education: medium	1998	8	6
	2002	7	6
Education: high	1998	13	9
	2002	14	12
Left	1998	9	6
	2002	11	11
Social Democrats	1998	5	4
	2002	7	5
Greens	1998	0	0
	2002	11	3
Center	1998	6	3

of correlations as traditional print and broadcast media: high consumption goes hand in hand with knowledgeability and trust in politicians.

Blogs as a phenomenon have already shown their potential as an agent of opinion formation and their ability to affect the course of campaigns, but they are not yet a mass phenomenon. Survey research findings from the SOM Institute in Fall 2005 indicate that about 60 per cent of the Swedish people did not know what a blog was, and 4 per cent said they vis-

		Visited a party's website before election	Visited an MP's website in recent years
	2002	4	4
Liberal	1998	18	5
	2002	12	7
Christian Democrats	1998	11	11
	2002	5	9
Moderate	1998	13	11
	2002	14	13
No preference	1998	0	0
	2002	4	4
Great/fairly great	1998	11	8
interest in politics	2002	12	10
Not much/not at all	1998	4	3
interested in politics	2002	3	4
High/fairly high trust	1998	14	10
	2002	11	9
Low/rather low trust	1998	5	4
	2002	6	6
Party identification	1998	9	7
	2002	11	9
No party identification	1998	7	4
	2002	7	6
Good political knowledge	1998	10	7
	2002	11	11
Poor political knowledge	1998	5	4
	2002	5	4

For knowledge index, see Table 4.1. *Source:* Swedish Election Studies.

Table 5.2 Reading of blogs.

Percentage who has read blogs written by:	
A private person	7
A journalist	7
A celebrity	4
A politician	4
Any of the above during the past 12 months	10

Share of the population who have read one or more blogs during past 12 months 2005.

Source: Bergström (2006). Mail survey Fall 2005 of nationally representative sample between the ages of 18 and 85 years. SOM Institute, University of Göteborg, www.som.gu.se

ited a blog once a week or more often (Bergström 2006). As Table 5.2 indicates, very few people read blogs. Less than 5 per cent of the respondents reported having read a blog published by a politician during the past year.

The new media and the citizens

What new information and communications technologies may mean for democracy has been widely debated. Such debates are often characterized by romantic notions of »revolutions« in this or that or, conversely, of so-called »moral panics«. Radio, television, video and computer games – all elicited moral panics when they were novelties.

There is not much in the way of consensus with regard to the importance Internet may have for democracy. »Utopians« point to a possible liberation from the structures that enforce social distinctions (class, race, gender), and to the emergence of grassroots activism, dialogic democracy, and new, transcendental communities. Internet is seen as one of the fora that provide a counterculture or alternative public sphere where subordinated and marginalized groups can generate public opinion. The web also opens up new ways of

confirming collective identities. »Dystopians« see instead a widening of information gaps, the opening of a »digital divide« and a further fragmentation that threatens to conserve or even worsen inequalities of power and influence in society (see, for example, Dahlgren 2002).

One problem with the Internet research to date is that, like all inquiry in the social sciences, it aims at a moving target – and a very fast-moving one at that. In less than a decade Internet has progressed from a novelty that few Swedes had access to, to a mass medium that the great majority use frequently.

Sociologist and media researcher Peter Dahlgren is among the cautious optimists. He believes that Internet can in the longer term contribute to the development of a civic culture. Internet can broaden the public sphere, serving as a resource for anyone who wishes to take part in public discourse, generate opinion, arrange activities and organize actions (Dahlgren 1999). At the same time, he sees few indications that the web will revolutionize political life. »Interactive, horizontal communication for political purposes will probably continue to be the domain of a small minority of activists and highly committed citizens« (Dahlgren 1999:155).

Political scientist Pippa Norris draws similar conclusions. She definitely believes in the potential of the web, but it is primarily those who already are interested and involved in political life who will benefit from the information, the opportunities to express themselves, and the mobilization potential the web offers (Norris 2001).

Another important conclusion is that the web is not likely to develop into a deliberative forum where different interest groups engage in dialogue (Norris 2001). There is rather a risk that cyber-politics will further fragment political discourse and strengthen special interests. The web can broaden and facilitate communication within groups, but hardly between groups – which tends to undermine rather than serve

the public interest. As Norris sees it, those who will primarily benefit from cyber-participation are political groups in the margins (fringe parties, protest movements and other alternative social movements) and especially groups whose activism focuses on issues that appeal to people who use the web – at present Liberal and Left-leaning views rather than Conservative ones (Norris 2001).

Peter Dahlgren points out that even though politically conservative individuals may use the web less than others, they are more ambitious, better organized and better financed when it comes to establishing a presence on the web for political purposes (Dahlgren 2001). Roughly one-fifth of the websites that focus on politics represent organizations outside the mainstream of political life, which is to say, the web does in fact help to expand the bounds of the public sphere (Hill & Hughes 1998).

A new kind of campaign?

Views as to the importance of the web to the future of democracy vary widely, among both researchers and the general public. Will the web have a only a minor impact, or will it revolutionize politics? Will the consequences be positive or negative on balance? »Minimalists« reduce both hopes and fears when they posit that the web is no more than a complement that reinforces existing media and power structures. »Maximalists«, for their part, talk about the emergence of a whole new social order.

Experience to date shows that the web and the new means of communication it has made possible do not fit easily into established theoretical models and patterns of thought. Earlier in this report we defined three different kinds of election campaigns: the pre-modern, the modern and the post-modern. These categories are also in alignment with the conceptu-

al framework that prevails in the international research literature. In our view, the classification needs to be complemented so as to encompass the new phenomena that are becoming increasingly common in contemporary election campaigns.

A theoretical construction of the kind presented here is based on the special logic that characterizes certain campaigns. The schema is not intended to describe any particular campaign, nor do the categories necessarily reflect any given period in time or specific media system. Different periods have their characteristic logics; still, history is full of lags and hybrid forms.

As Figure 5.1 shows, the web can be seen to represent a new kind of election campaign, different from the three established models in fundamental respects.

The facility with which new communications technologies form and maintain networks may lay the foundation for heretofore unknown kinds of political parties, but it may also

	Logic			
	Party logic	Media logic	Market logic	Network logic
Parties	Membership party Product orientation	Campaign party Sales orientation	Market party Market orientation	Network party Network orientation
Voters	Loyal groups Class	Mass public Issues	Target groups Lifestyles	Web communities Common values
Media	Partycontrolled media	Journalistic mass media	Niche marketing	Citizen journalism
Locus of opinion formation	Speaker's podium	Editorial board	Consultant	Internet

Figure 5.1 A fourth type of election campaign?

revitalize existing organizations. Thus, this model forms a contrast to both the pre-modern party-oriented membership parties and campaign parties, imbued with the logic of the media. They differ from market-oriented parties, as well.

The four kinds of parties are associated with different approaches to public opinion. In the first case, party-controlled media are central, and the speaker's podium is emblematic. Characteristic of the logic of the media are journalist-steered media, the epitome of which is the television news department. PR consultants are pivotal figures in campaigns run according to the logic of the market; these campaigns make use of a mix of a variety of niche channels for marketing the party to specified target groups. In the logic of the network, finally, the web is the central means of communication. Examples of the new 'citizen journalism' are www.ohmynews.com and www.politicsonline.com. Some features of the current trend blur the conventional distinction between voters and the media. May future voters each become his or her own medium?

It goes without saying that the four models are but theoretical constructions. Real-life exemplars of the models may vary widely between periods in time, countries, campaigns and parties. The least-explored category is, of course, the logic of the network. It remains to be seen whether networking mainly supplements one or more of the older models or will one day dominate entire campaigns.

6. Election Campaigns in the Future

In the foregoing chapters we have analyzed election campaigns from three points of view: the voters', the parties' and the media's. A recap of international variations and courses of development over time gives rise to some reflections on how future election campaigns may be conducted.

Voters

A survey of the election campaigns of the past half-century raises the question, if voters are wiser and more enthusiastic today than in the past.

Fairly well-informed...

Some attempts have been made to gauge the level of knowledge of Swedish voters, but the studies have encountered serious problems regarding definitions and measures. The findings are far from conclusive.

Those who are looking for evidence that voters are ignorant might turn to the findings of interviews where respondents have been asked about miscellaneous simplefacts. Correct answers to knowledge questions are generally found among older, well-educated groups. A good portion of the public are unable to name the leading officials in their local government or to characterize draft legislation presented during the past week. What is more, they often confuse

the Government and the Riksdag and have only vague ideas about what the county councils do.

Not to be discouraged, election researchers have tried other means to measure voters' awareness. Some findings are more encouraging. Individual voters are not only able to find their way to the polling station and to sort the multicolored voting bills into the right envelopes; interview studies reveal that surprisingly often the platforms of the parties they vote for coincide with their personal hopes, fears, dreams and demands.

In the terminology of election research class voting has become less common as tradition-bound party loyalties give way to more questioning issue-based voting behavior. We found no indication that political leaders' charisma or other personal traits to any appreciable extent influence Swedish voters' choices, or even that such influences might be growing.

...but more or less indifferent...

There are surely voters who cast their votes with enthusiasm, but they are few. The vast majority vote out of duty, and those who are drawn to the polls by the magnetism of one or another party are rare indeed. If the alternatives seem all too bland and diffuse, voters may simply decide not to bother. As the low turnout in the 2004 elections to the European Parliament (37.9 per cent) demonstrate, even Swedish voters' sense of civic duty has its limits.

Survey research has also made it clear that politicians as a collective are not held in very high esteem these days. To speak of contempt or scorn would be to exaggerate; few people care enough about politics to muster the adrenaline that true contempt requires. It is rather a matter of world-weary skepticism: a mildly critical attitude and no great expectations.

...spectators

Among the findings that have surprised us are those from international comparisons of citizens' personal involvement in election campaigns. That American voters lead the league is surprising enough, but that today's Swedes, grandchildren of the popular movement model, should rank so resoundingly last is surprising, yes, but also a bit troubling.

In recent decades voters have proven to be increasingly promiscuous, doubtful, skeptical – in short, unpredictable. Even if election turnouts remain on a relatively high level by international comparison (80.1 per cent in the 2002 Riksdag election), the trend over the past three decades has been slightly, but steadily downward. Lower election turnouts have revealed widening gaps in Swedish society. Political inequality is becoming increasingly apparent, and in the longer term we risk finding ourselves in a so-called »two-thirds democracy«. Even if the parties' campaign messages and journalists' reports and commentary still reach most voters, there are groups – particularly in the poor suburbs of Sweden's three metropolitan cities – who de facto stand outside democratic society.

Parties

Many books and articles on political parties, academic works as well as more journalistic accounts, speak of their »crisis« and »decline«. The variations on the theme, »the party is over,« are innumerable.

Clearly, parties do have problems. In the preceding chapters we have noted declining memberships and weaker party identification in the electorate. But it is entirely too soon to count them out. In some respects they are still extremely vital, and not only thanks to generous public subsidies.

Membership, campaign, market, network...

Trying to conceive of democracy without parties is a futile exercise. Democracy needs parties, in some form or another. In assuming an overarching social responsibility the parties provide training in resolving conflicts and dilemmas through discussion and negotiation

This is not to say that parties need have the same character and organization as they have at present. Experience tells us that developments in the media sector have a strong impact on political parties, but also that parties are quick to adapt to the new situations.

In election campaigns parties diversify, adopting new characters and *modi operandi* as the situation demands: membership party, campaign organization, market party, network party. Current trends in the media sector do indeed pose challenges, but they also present new, potentially revitalizing opportunities.

New opportunities

Journalists gained control over election programming in Swedish radio and television in the 1960s. Since then, the parties have been dependent on the media in order to reach out to the great mass of voters. The media's power was perhaps especially strong in Sweden inasmuch as parties have neither the opportunity to present themselves to the public in programs of their own making nor the alternative of buying air time on the principal television channels.

With a proliferation of new media, the power of mass media might be waning. New channels of communication have opened up. Research data suggest that the parties' direct communication with voters will stimulate voters' knowledge and interest in politics. It remains to be seen to what extent the parties are aware of the potential and able to exploit the opportunities now available to them to reach out to selected

demographic groups, not least young people. The web offers means to revitalize democratic decision-making within the parties, as well.

Media

For decades now, journalistic mass media have been responsible for nearly all the election information that reaches the general public during an election campaign. Election coverage continues to be a priority for most mainstream media in Sweden. Journalistic coverage of election campaigns continues, but the conditions under which news media operate may be changing in several vital respects.

Differentiation and commercialization

Whereas journalism has gradually freed itself from party political allegiances, the ongoing differentiation and commercialization of Swedish mass media mean that quality journalism is under increasing pressure. Meanwhile, the competition for public attention has become ever keener.

It is more and more a delusion to conceive of mass media as a uniform category. The nature and tenor of election coverage varies widely between different kinds of media. Some media, such as public service radio and television and selected leading nationally distributed newspapers, inform and enlighten their audiences and readers, whereas others, some commercial television channels and tabloids, are rather associated with ignorance and cynicism among the citizenry.

Entertainment and 'personalities'

The overall trend in contemporary journalism toward entertainment and a focus on celebrities and others in the public eye has left an imprint on election coverage (public service media included), as well.

'Media twists' have become more marked in some cases, but not in others. Personification plays a greater role in news journalism, as does a skeptical attitude toward politicians as a group, but there are no consistent tendencies toward greater reliance on the framing of politics as a game or an emphasis on polarization or conflict.

Election coverage in the form of news reports, interviews/question-and-answer sessions, and debates is not the only media content of importance to parties' campaigns. Politics and politicians are featured directly and indirectly in entertainment genres, as well. Politics is popularized, popular culture politicized.

Interpretive journalism in the ascendant

Swedish journalistic media abandoned all ambitions to mirror political events and processes in a neutral fashion long ago. The trend has been toward increasingly interpretive, and primarily critically interpretive, reporting.

Interpretive journalism can take a variety of forms. In the case of speculation, for example, instead of reporting what has happened, the journalist ventures to predict what is going to happen. In the case of news analysis, journalists, donning the role of critical expert, explain events and processes in terms of politicians' strategies and motives and tell their readers and audiences who is likely to gain (or lose) as a result. Commentators, for their part, are free to express their personal views, prejudices and preferences without any pretense of neutrality.

Election campaigns

In the course of our work on this book we have time and again had cause to remark on how dated and bound-to-specifics many accounts of election campaigns are. On an overarching plane there is, of course, continuity, and some features remain stable over time. Still, it is very difficult to draw general conclusions concerning campaigns as processes or in what direction they may be evolving.

No Americanization

After systematic study, there is not much left of the oft-heard proposition that Swedish election campaigns have undergone a successive 'Americanization'. International comparisons of media systems reveal no singular trend. There are major differences between the 'polarized pluralism' of Italian media and the northern European public service broadcasting models. Election campaigns can differ widely.

Hybridization

We may speak of different basic models: party-oriented, campaign-oriented, market-oriented and network-oriented. In reality, however, every campaign is a mixture of these basic models. Political rallies of the party-oriented campaign may very well be combined with television exposure of the sales-oriented model.

Permanent campaigns

The fickleness of modern voters means that elections are sometimes decided only days before Election Day. Campaigns, however, extend over ever longer periods of time, and when they start has become harder to pinpoint. Consequent-

ly, the interactions between parties, media and voters during the campaign influence the entire democratic process.

Unpredictable campaigns

Swedish voters are heavily dependent on the media for their contacts with the political sphere. Several factors contribute to make it difficult to make any predictions about the future. Voters themselves are increasingly unpredictable, deciding late in the campaign, changing their minds, and switching party preferences at will. Parties are less predictable due to the emergence of new parties, new political constellations and alliances, and the growing influence of politics and policy on the European level. Media, too, are less predictable: the logic of the media can lead in different directions; competition is keener, with increasing numbers of channels and actors competing for attention.

New constellations of power

Clearly, we stand on the threshold of comprehensive changes, not least when it comes to power relationships between voters, parties and media.

The power of mass media and journalists may already have peaked. Meanwhile, new media, constituting potential power bases for other groups, are emerging.

Today, political parties have access to new channels of communication and can free themselves from having to maintain visibility in journalistic media. But it remains to be seen whether established parties will be able to take advantage of these new opportunities. Perhaps new kinds of parties – perhaps even antidemocratic movements – will be more alert to them and thus supplant the older parties.

The power of the voter is on the rise by virtue of both politicians' and media's sensitivity to consumer demand and

popular tastes. Whether this greater measure of ‘power to the people’ will result in a more responsive system is another question.

In a fifty-year perspective

We started with a quote from Jörgen Westerståhl’s and Bo Särilvik’s pioneering work on election campaigns from 1956, and we return to that work by way of conclusion. Some profound changes have taken place in the span of fifty years.

This past half-century may be seen to constitute an epoch of journalist-steered mass media. Television contributed immensely to processes of democratic communication and gave journalists a unique position of power. The lesson to be learned here is that changes in the media landscape are closely related to changes in the nature of election campaigns.

The period is characterized by the power of mass media in relation to election campaigns in two respects: the media were able to choose how the parties and politics would be portrayed, and the media exerted strong influence over the conduct of campaigns.

We note indications that the epoch of media power is nearing its end, that a new phase is in the offing. As yet the tendencies are weak and partly contradictory, but there is good reason for us all to start thinking about what election campaigning may be like in years to come.

References

- Aardal, Bernt, Anne Krogstad and Hanne Marthe Narud, eds. (2004). *I valgkampens hete. Strategisk kommunikasjon og politisk usikkerhet*. Universitetsforlaget, Oslo.
- Abramsson, Erika and Jesper Strömbäck (2004). *EU-parlamentsvalet: en god eller dålig nyhet?* Demokratiinstitutet, Sundsvall.
- Altheide, David L. and Robert P. Snow (1979). *Media Logic*. Sage, Beverly Hills.
- Andén-Papadopoulos, Kari (2003). *Dold kamera. I sanningens tjänst?* Institutet för Mediestudier, Sellin & Partner, Stockholm.
- Andersson Odén, Thomas, Marina Ghersetti and Ulf Wallin (2005). *Tsunamins genomslag. En studie av svenska mediers bevakning*. Krisberedskapsmyndigheten, Stockholm.
- ANES (2005). American National Election Studies. www.umich.edu/~nes
- Asp, Kent (1986). *Mäktiga massmedier. Studier i politisk opinionsbildning*. Akademitratur, Stockholm.
- Asp, Kent (1995). *Kommersialiserade TV-nyheter på gott och ont. Jämförande undersökning av Rapport TV2 och Nyheterna TV4*. Institutionen för journalistik och masskommunikation, Göteborgs universitet.
- Asp, Kent (2001). »Journalisternas politiska åsikter«, in Marina Ghersetti, ed. *Journalist 2000*. Institutionen för journalistik och masskommunikation, Göteborgs universitet.
- Asp, Kent (2003). *Medieval 2002. Partiskheten och valutgången. En studie av valrörelsens medialisering*. Institutionen för journalistik och masskommunikation, Göteborgs universitet.
- Asp, Kent and Peter Esaiasson (1996). »The modernization of Swedish campaigns: individualization, professionalization, and medialization«, in Swanson and Mancini, eds. (1996).
- Asp, Kent and Bengt Johansson (1999). »Medierna och personvalet«, in Sören Holmberg and Tommy Möller, eds. *Premiär för personval*. SOU 1999:92.
- Bennett, W. Lance and Robert M. Entman, eds. (2001). *Mediated Politics. Communication in the Future of Democracy*. Cambridge University Press, Cambridge.

- Bergström, Annika (2004). »Internet«, in Ulla Carlsson and Ulrika Facht, eds. *MedieSverige 2004*. Nordicom, Göteborgs universitet.
- Bergström, Annika (2006). »Nyheter, bloggar och offentliga sajter«, in Holmberg and Weibull (2006).
- Bergström, Annika, Ingela Wadbring and Lennart Weibull, eds. (2005). *Nypressat. Ett kvartssekel med svenska dagstidningsläsare*. Institutionen för journalistik och masskommunikation, Göteborgs universitet.
- Blumenthal, Sidney (1980). *The Permanent Campaign. Inside the World of Elite Political Operatives*. Beacon Press, Boston.
- Blumler, Jay G. (1997). »Origins of the crisis of communication for citizenship«, *Political Communication*, 14, 395–404.
- Blumler, Jay G. and Michael Gurevich (2001). »'Americanization' reconsidered: U.K.–U.S. communication comparisons across time«, in Bennett and Entman (2001).
- Blumler, Jay G. and Dennis Kavanagh (1999). »The third age of political communication: influences and features«, *Political Communication*, 16, 209–230.
- Brants, Kees (1998). »Who's afraid of infotainment?« *European Journal of Communication*, 13, 315–335.
- Bretschneider, Frank (2005). »Bundestagswahlkampf und Medienberichterstattung«, *Aus Politik und Zeitgeschichte*, nr 51–52, 19–26.
- Buchanan, Bruce I. (2001). »Mediated electoral democracy: campaigns, incentives, and reform«, in Bennett and Entman (2001).
- Campbell, Angus, Philip E. Converse, Warren E. Miller and Donald E. Stokes (1960). *The American Voter*. Wiley, New York
- Campbell, James E. (2000). *The American Campaign. U.S. Presidential Campaigns and the National Vote*. Texas A&M University Press, College Station, Texas.
- Cappella, Joseph N. and Kathleen Hall Jamieson (1997). *Spiral of Cynicism. The press and the Public Good*. Oxford University Press, New York.
- Carpini, Michael Delli and Bruce A. Williams (2001). »Let us infotain you: politics in the new media environment, in Bennett and Entman (2001).

- Ceaser, James W. and Andrew E. Busch (2005). *Red over Blue. The 2004 Elections and American Politics*. Rowman & Littlefield, Lanham.
- Cicero, Quintus Tullius (64 f. Kr.). *Commentariolum petitionis*. Fr. övers. *Essai sur la candidature*.
- Cook, Timothy E. (1998). *Governing with the News. The News Media as a Political Institution*. University of Chicago Press, Chicago.
- Croteau, David and William Hoynes (2001). *The Business of Media. Corporate Media and the Public Interest*. Pine Forge Press, Thousand Oaks.
- CSES (2005). The Comparative Study of Electoral Systems. www.umich.edu/~cses
- Dahlgren, Peter (1999). »EU, medborgarkultur och mediernas demokratiska uppgift«, in *Politikens medialisering*, SOU 1999: 126.
- Dahlgren, Peter (2001). »The public sphere and the net«, in Bennett and Entman (2001).
- Dahlgren, Peter, ed. (2002). *Internet, medier och kommunikation*. Studentlitteratur, Lund 2002.
- Dahlgren, Peter and Colin Sparks, eds. (1992). *Journalism and Popular Culture*. Sage, London.
- Denton, Jr., Robert E. ed. (2005). *The 2004 Presidential Campaign. A Communication Perspective*. Rowman & Littlefield, Lanham.
- de Vreese, Claes H. (2004). »The effects of strategic news on political cynicism, issue evaluations, and policy support: a two-wave experiment«, *Mass Communication & Society*, 7, 191–214.
- Djerf-Pierre, Monika (2001). »Skjutjärn, pedagog eller hantverkare«, in Marina Ghersetti, ed. *Journalist 2000*. Institutionen för journalistik och masskommunikation, Göteborgs universitet.
- Djerf-Pierre, Monika and Lennart Weibull (2001). *Spegla, granska, tolka. Aktualitetsjournalistik i svensk radio och TV under 1900-talet*. Prisma, Stockholm.
- Djerf-Pierre, Monika and Lennart Weibull (2005). *Par Condicio? Politisk partiskhet i italienska medier*. Arbetsrapport till SNS Demokratiråd. SNS, Stockholm. www.sns.se
- Dörner, Andreas and Ludgera Vogt, eds. (2002). *Wahl-Kämpfe. Betrachtungen über ein demokratisches Ritual*. Suhrkamp, Frankfurt.

- Edström, Maria (2006). *TV-rummets eliter*. Institutionen för journalistik och masskommunikation, Göteborgs universitet.
- Ekecrantz, Jan and Tom Olsson (1994). *Det redigerade samhället. Om journalistikens, beskrivningsmaktens och det informerade förnuftets historia*. Carlssons, Stockholm
- Ekström, Mats (1999). »TV-tittarna och demokratin«, in *Politikens medialisering*, SOU 1999:126.
- Ekström, Mats and Cathrin Andersson (1999). »När väljarna ska mobiliseras. Valrörelsen 1998 i ett jämförande perspektiv«, in SOU 1999:132.
- Elgemyr, Göran (1984). »Radion och det journalistiska oberoendet«, in Jörgen Cederberg and Göran Elgemyr, eds. *Tala till och tala med. Perspektiv på den svenska radion och televisionen*, Legenda, Stockholm.
- Esaiasson, Peter (1990). *Svenska valkampanjer 1866–1988*. Allmänna förlaget, Stockholm.
- Esaiasson, Peter and Nicklas Håkansson (2002). *Besked ikväll! Valprogrammen i svensk radio och tv*. Stiftelsen Etermedierna i Sverige, Stockholm.
- Esser, Frank, Carsten Reinemann and David Fan (2000). »Spin doctoring in British and German election campaigns: how the press is being confronted with a new quality of political PR«, *European Journal of Communication*, 5, 209–239.
- Eurobarometer (2004). *Post European Elections 2004 Survey*. Flash Eurobarometer 162. europa.eu.int/comm/public_opinion/flash/FL162en.pdf
- Farnsworth, Stephen J. and Robert S. Lichter (2006). *The Mediated Presidency. Television News and Presidential Governance*. Rowman & Littlefield, Lanham.
- Farrell, David and Paul Webb (2000). »Political parties as campaign organizations«, in Russel Dalton and Martin P. Wattenberg, eds. *Parties without Partisans*, Oxford University Press, Oxford.
- Franklin, Bob (2004). *Packaging Politics. Political Communications in Britain's Media Democracy*. Second ed. Arnold, London.
- Furhoff, Lars (1963). *Pressens förräderi. Om tredje statsmakten i landsorten*. Bonniers, Stockholm.

- Ghersetti, Marina (1982). *Svensk politisk journalistik under 1900-talet*. Informationsteknik, Göteborgs universitet.
- Ghersetti, Marina (2004). »Sensationsjournalistikens mekanismer«, in Lars Nord and Jesper Strömbäck, eds. *Medierna och demokratin*. Studentlitteratur, Lund.
- Gibson, Rachel and Andrea Römmele (2001). »Changing campaign communications: a party-centered theory of professionalized campaigning«, *The Harvard International Journal of Press/Politics*, 6, 31–43.
- Gilljam, Mikael and Sören Holmberg (1995). *Väljarnas val*. Norstedts Juridik, Stockholm.
- Gilljam Mikael and Sören Holmberg, eds. (1996). *Ett knappt ja till EU. Väljarna och folkomröstningen 1994*. Norstedts Juridik, Stockholm.
- Graber, Doris A. (2006). *Mass Media and American Politics*. Seventh ed. Congressional Quarterly Press, Washington DC.
- Gulati, Girish J., Marion R. Just and Ann N. Crigler (2004). »News Coverage of Political Campaigns«, in Lynda Lee Kaid, ed. *Handbook of Political Communication Research*. Lawrence Erlbaum Associates, Mahwah, NJ.
- Hadenius, Stig, Jan-Olof Seveborg and Lennart Weibull (1968). *Socialdemokratisk press och presspolitik 1899–1909*. Tiden, Stockholm.
- Hadenius, Stig, Jan-Olof Seveborg and Lennart Weibull (1970). *Partipress. Socialdemokratisk press 1910–1920*. Rabén&Sjögren, Stockholm.
- Hadenius, Stig and Lennart Weibull (2005). *Massmedier. En bok om press radio tv*. Eighth ed. Bonniers, Stockholm.
- Hallin, Daniel C. (1992). »Sound bite news: television coverage of elections, 1968–1988«, in *Journal of Communication*, 42, 5–24.
- Hallin, Daniel C. and Paolo Mancini (2004). *Comparing Media Systems. Three Models of Media and Politics*. Cambridge University Press, Cambridge.
- Hamilton, James T. (2004). *All the News That's Fit To Sell. How the Market Transforms Information Into News*. Princeton University Press, Princeton, NJ.

- Heath, Robert L. (1997). *Strategic Issues Management. Organizations and Public Policy Challenges*. Sage, Thousand Oaks.
- Hermansson, Jörgen, Anna Lund, Torsten Svensson and PerOla Öberg (1999). »Avkorporativisering och lobbyism: konturerna till en ny politisk modell«, in SOU 1999:121.
- Hernes, Gudmund (1975). *Makt og avmakt. En begrepsanalyse*. Universitetsforlaget, Bergen.
- Hernes, Gudmund (1978). »Det mediavridde samfunn«, in Gudmund Hernes, ed. *Forhandlingsøkonomi og blandingsadministrasjon*. Universitetsforlaget, Oslo.
- Hill, Kevin A. and John E. Hughes (1998). *Cyberpolitics. Citizen Activism in the Age of the Internet*. Rowman & Littlefield, Lanham.
- Holmberg, Sören (1994). »Partierna tycker vi bäst om i valtider«, in Sören Holmberg and Lennart Weibull, eds. *Vägval*. SOM-rapport 11, Göteborgs universitet.
- Holmberg, Sören (2000). *Välja parti*. Norstedts Juridik, Stockholm.
- Holmberg, Sören and Kent Asp (1984). *Kampen om kärnkraften. En bok om väljare, massmedier och folkomröstningen 1980*. Liber, Stockholm.
- Holmberg, Sören and Henrik Oscarsson (2004). *Väljare. Svenskt väljarbeteende under 50 år*. Norstedts Juridik, Stockholm.
- Holmberg, Sören and Lennart Weibull, eds. (2005). *Lyckan kommer, lyckan går*. SOM-rapport 36, Göteborgs universitet.
- Holmberg, Sören and Lennart Weibull, eds. (2006). *Du stora nya värld*. SOM-rapport 39, Göteborgs universitet.
- Holtz-Bacha, Christina and Lynda Lee Kaid (2006). »Political advertising in international comparison«, in Lynda Lee Kaid and Christina Holtz-Bacha, eds. *The Sage Handbook of Political Advertising*. Sage, London.
- Håkansson, Nicklas (1999). *Valretorik. Om politiskt språk i parti-propagandan*. Göteborg Studies in Politics 65. Statsvetenskapliga institutionen, Göteborgs universitet.
- Isaksson, Jenny and Steffanie Müller (2003). *Blogging. Virtuella offentliga samtal*. Journalistik, Södertörns högskola.
- Iyengar, Shanto (1991). *Is Anyone Responsible? How Television Frames Political Issues*. University of Chicago Press, Chicago.

- Iyengar, Shanto and Kinder, Donald R. (1987). *News that Matters. Television and American Opinion*. University of Chicago Press, Chicago.
- Johansson, Bengt (2001). *När opinionen ska förklaras. Valutgång och väljaropinion i svensk dagspress under valrörelsen 1998*. Demokratiinstitutet, Sundsvall.
- Johansson, Bengt (2006). »Blir kampanjen bättre ju närmare valdagen vi kommer?«, in Hanna Bäck and Mikael Gilljam, eds. *Valets mekanismer*. Liber, Stockholm.
- Johansson, Folke (1977). *Sverige partipolitiseras. Dagspressen som en spegel av politisk utveckling 1896–1908*. Gleerups, Lund.
- Johansson, Martin (2001). *En medialiserad bild av valrörelsen? Institutionen för journalistik och masskommunikation, Göteborgs universitet*.
- Johansson, Martin (2005). *Amerikanisering i Sverige? En undersökning av tre partiers uttryck i svenska valkampanjer 1948–2002*. Statsvetenskapliga institutionen, Göteborgs universitet.
- Jones, Jeffrey P. (2005). »The shadow campaign in popular culture«, in Denton (2005).
- Jönsson, Anna Maria and Jesper Strömbäck (2007). *TV-journalistik i konkurrens. Nyhets- och samhällsprogram i svensk TV 1990–2004*. Ekerlids förlag, Stockholm.
- Jönsson, Anna-Maria and Henrik Örnebring (2004). »Tabloid journalism and the public sphere: a historical perspective on tabloid journalism«, *Journalism Studies*, 5, sid. 283–295.
- Jönsson, Rasmus and Ole Larsen (2002). *Professionel politisk kommunikation. Et studie af 20 dages valgkamp*. Akademisk forlag, Köpenhamn.
- Kaid, Lynda Lee (1999). »Comparing and contrasting the styles and effects of political advertising in European democracies«, in Lynda Lee Kaid, ed. *Television and Politics in Evolving European Democracies*. Nova Science Publishers, Commack.
- Kaid, Lynda Lee (2004). »Political advertising«, in Lynda Lee Kaid, ed. *Handbook of Political Communication Research*. Lawrence Erlbaum, Mahwah, NJ.
- Kaid, Lynda Lee and Christina Holtz-Bacha, eds. (1995). *Political Advertising in Western Democracies. Parties and Candidates on Television*. Sage, London.

- Karlsen, Rune and Hanne Marthe Narud (2004). »Organisering av valkampen: 'tradisjonell' eller 'moderne?«, in Aardal, Krogstad and Narud (2004).
- Kirchheimer, Otto (1966). »The transformation of Western European party systems«, in Joseph LaPalombara and Myron Weiner, eds. *Political Parties and Political Development*. Princeton University Press, Princeton.
- Koblik, Steven (1980). »Towards an analytical model for Swedish election campaigns«, *Statsvetenskaplig tidskrift*, 83, 23–36.
- Kronvall, Kai (1975). *Partipressen idag*. Studentlitteratur, Lund.
- Larsson, Larsåke (2005a). *Opinionsmakarna. En studie om PR-konsulter, journalistik och demokrati*. Studentlitteratur, Lund.
- Larsson, Larsåke (2005b). *Upplysning och propaganda. Utvecklingen av svensk PR och information*. Studentlitteratur, Lund.
- Lavrakas, Paul J. and Michael W. Traugott, eds. (2000). *Election Polls, the News Media, and Democracy*. Chatham House, New York.
- Lazarsfeld, Paul F., Bernard Berelson, Hazel Gaudet (1944). *The People's Choice. How the Voter Makes up His Mind in a Presidential Campaign*. Duell, Sloan and Pearce, New York.
- Lees-Marshment, Jennifer (2001). *Political Marketing and British Political Parties*. Manchester University Press, Manchester.
- Lees-Marshment, Jennifer (2004). *Political Marketing. The Key to Electoral Success or the Cause of Democratic Turmoil?* Demokratiinstitutet, Mittuniversitetet, Sundsvall.
- Leijonhufvud, Jonas and Martin Jönsson (2006). »150 partimiljoner i potten« *Svenska Dagbladet*, 23 januari 2006.
- Lilleker, Darren G. and Jennifer Lees-Marshment, eds. (2005). *Political Marketing. A Comparative Perspective*. Manchester University Press, Manchester.
- Lowry, Dennis T. and Jon A. Shidler (1999). »The sound bites, the biters, and the bitten: a two-campaign test of the anti-incumbent bias hypothesis in network TV news«, *Journalism & Mass Communication Quarterly*, 75, 33–44.
- Lundell, Malin & Anders Olson (2005). »Vad handlar det här egentligen om?« *En studie om SVT:s inrikespolitiska expertkommentatorer*. Institutionen för journalistik och masskommunikation, Göteborgs universitet.

- Mancini, Paolo (2006). »Political professionalism in Italy«. Draft. University of Perugia.
- Mazzoleni, Gianpietro (2006). »TV political advertising in Italy: when politicians are afraid«, in Lynda Lee Kaid and Christina Holtz-Bacha, eds. *The Sage Handbook of Political Advertising*. Sage, London.
- McCombs, Maxwell, Donald L. Shaw and David Weaver eds. (1997). *Communication and Democracy. Exploring the Intellectual Frontiers in Agenda-Setting Theory*. Lawrence Erlbaum Associates, Hillsdale, NJ.
- McCombs, Maxwell (2006). *Makten över dagordningen*. SNS Förlag, Stockholm.
- McManus, John H. (1994). *Market-Driven Journalism. Let the Citizen Beware?* Sage, Thousand Oaks.
- McNair, Brian (2000). *Journalism and Democracy. An Evaluation of the Political Public Sphere*. Routledge, London.
- McQuail, Denis (2005). *McQuail's Mass Communication Theory*. Fifth ed. Sage, Beverly Hills-London.
- Mazzoleni, Gianpietro (2006). »TV political advertising in Italy: when politicians are afraid«, in Lynda Lee Kaid and Christina Holtz-Bacha, eds. *The Sage Handbook of Political Advertising*. Sage, London.
- Meyer, Thomas (2002). *Media Democracy. How the Media Colonize Politics*. Polity Press, Cambridge.
- Negrine, Ralph M. and Darren G. Lilleker (2002). »The professionalization of political communication: continuities and change in media practices«, *European Journal of Communication*, 17, 305–323.
- Neveu, Erik (2002). »Four generations of political journalism«, in Raymond Kuhn and Erik Neveu, ed. *Political Journalism. New Challenges, New Practices*. Routledge, London.
- Nord, Lars (2006). »Still the middle way: a study of political communication practices in Swedish election campaigns«, *The Harvard International Journal of Press/Politics*, 11, 64–76.
- Nord, Lars and Jesper Strömbäck (2003). *Valfeber och nyhetsfrossa. Politisk kommunikation i valrörelsen 2002*. Institutet för mediestudier, Sellin & Partner, Stockholm 2003.

- Nord, Lars & Jesper Strömbäck (2006). »Game is the name of the frame. European parliamentary elections in Swedish media 1995–2004«, in Michaela Maier and Jens Tenscher, eds. *Campaigning in Europe – Campaigning for Europe. Political Parties, Mass Media and the European Parliament Elections 2004*. LIT Verlag, Münster.
- Nordström, Bengt (2005). Information from Bengt Nordström, Sveriges Television.
- Norris, Pippa (1997). »The rise of postmodern political communication?«, in Pippa Norris, ed. *Politics and the Press. The News Media and Their Influences*. Lynne Rienner, Boulder.
- Norris, Pippa (2000). *A Virtuous Circle. Political Communications in Postindustrial Societies*. Cambridge University Press, Cambridge.
- Norris, Pippa (2001). *Digital divide? Civic Engagement, Information Poverty, and the Internet Worldwide*. Cambridge University Press, Cambridge.
- Nygren, Gunnar (2001). »Vi mot dom«, in Håkan Hvitfelt and Lauri Karvonen, eds. *Demokratins konflikter*, Demokratiinstitutet, Sundsvall.
- Observer (2005). *Bloggbubbla eller ny arena för opinionsbildning? Bloggarna och valet 2006*. Observer, Stockholm.
- Ohlsson, Anders (1989). *Politiska nyheter till nytta och nöje. En studie av varför vi tar del av nyheter om politik i press, radio och tv*. Göteborg Studies in Politics, 19, Almqvist & Wiksell, Stockholm.
- Ornstein Norman J. and Thomas E. Mann (2000). *The Permanent Campaign and its Future*. American Enterprise Institute, Brookings, Washington DC.
- Oscarsson, Henrik and Sören Holmberg, eds. (2004). *Kampen om euron*. Statsvetenskapliga institutionen, Göteborgs universitet.
- Oscarsson, Henrik and Sören Holmberg (2006). *Europaval*. Statsvetenskapliga institutionen, Göteborgs universitet.
- Patterson, Thomas E. (1993). *Out of Order*. Vintage Books, New York.
- Patterson, Thomas E. (1998). »Political roles of the journalist«, in Doris A. Graber, Denis McQuail and Pippa Norris, eds. *The Pol-*

- itics of News. The News of Politics*. Congressional Quarterly Press, Washington DC.
- Patterson, Thomas E. (2000). »The United States: news in a free-market society«, in Richard Gunther and Anthony Mughan, eds. *Democracy and the Media. A Comparative Perspective*. Cambridge University Press, New York.
- Perloff, Richard M. (1999). »Elite, popular, and merchandised politics: historical origins of presidential campaign marketing«, in Bruce I. Newman, ed. *Handbook of Political Marketing*, Sage, Thousand Oaks.
- Persson, Ingela and Christina Tellström (2002). *Från träbock till Leijonkung. En undersökning av hur folkpartiet och Lars Leijonborg framställdes i medierna under två valrörelser*. Medie- och kommunikationsvetenskap, Mittuniversitetet, Sundsvall.
- Petersson, Olof (2005). *De politiska partiernas medlemsutveckling*. Arbetsrapport till SNS Demokratiråd. SNS, Stockholm. www.sns.se
- Petersson, Olof and Ingrid Carlberg (1990). *Makten över tanken. En bok om det svenska massmediesamhället*. Carlssons, Stockholm.
- Petersson, Olof, Gudmund Hernes, Sören Holmberg, Lise Togeby and Lena Wängnerud (2000). *Demokrati utan partier? Demokratirådets rapport 2000*. SNS Förlag, Stockholm.
- Petersson, Olof and Sören Holmberg (1998). *Opinionsmätningarna och demokratin*. SNS Förlag, Stockholm.
- Petersson, Olof, Sören Holmberg, Johanna Laurin and Jesper Strömbäck (2005). *Spinndoktorernas läkarstämma*. Rapport till SNS Demokratiråd. Stockholm, SNS.
- Petersson, Olof, Monika Djerf-Pierre, Jesper Strömbäck and Lennart Weibull (2005). *Mediernas integritet. Demokratirådets rapport 2005*. SNS Förlag, Stockholm.
- Petersson, Olof and Sören Holmberg (2006). *Svenska partibarometrar. En dokumentation*. Rapport till SNS Demokratiråd. Stockholm, SNS.
- Plasser, Fritz and Gunda Plasser (2002). *Global Political Campaigning. A Worldwide Analysis of Campaign Professionals and Their Practices*. Praeger, Westport.

- Reese, Stephen D., Oscar H. Gandy Jr and August E. Grant, eds. (2001). *Framing Public Life. Perspectives on Media and our Understanding of the Social World*. Lawrence Erlbaum Associates, Mahwah, NJ.
- Semetko, Holli A., Jay G. Blumler, Michael Gurevitch and David H. Weaver (1991). *The Formation of Campaign Agendas. A Comparative Analysis of Party and Media Roles in Recent American and British Elections*. Lawrence Erlbaum Associates, Hillsdale.
- Sjödén, Rune (1962). *Sveriges första TV-val. En studie av radions och televisionens roll som propagandamedier under 1960 års valkampanj*. Sveriges Radio, Stockholm.
- SOU 1995:37. *Vårt dagliga blad. Stöd till svensk dagspress*.
- Stattin, Erik (2005). »Bloggar i nyhets- och opinionsbildningen«, in Våge, Stattin and Nygren (2005).
- Strömbäck, Jesper (2000). *Makt och medier. Om samspelet mellan medborgarna, medierna och de politiska makthavarna*. Studentlitteratur, Lund.
- Strömbäck, Jesper (2001). *Gäster hos verkligheten. En studie av journalistik, demokrati och politisk misstro*. Brutus Östlings bokförlag Symposion, Stockholm, Stehag.
- Strömbäck, Jesper (2004). *Den medialiserade demokratin. Om journalistikens ideal, verklighet och makt*. SNS Förlag, Stockholm.
- Strömbäck, Jesper and Daniela V. Dimitrova (2006). »The political and media systems matter: a comparison of election news coverage in Sweden and the United States«, *Harvard International Journal of Press/Politics*, under utgivn.
- Strömbäck, Jesper & Bengt Johansson (2006). Elections matter. A longitudinal study of the mobilizing effects of elections. Annual Conference of the International Communication Association, Dresden, juni 2006.
- Strömbäck, Jesper and Óscar G. Luengo (2006). Framing and Election News Coverage in Spain and Sweden. 4th International Symposium Communication in the Millenium, Eskisehir, Turket, juni 2006.
- Strömbäck, Jesper and Lars Nord (2006). »Still a second-order election: a comparison of the Swedish media coverage of the 2004 EP

- election and the 2002 national election», in Lynda Lee Kaid, ed. *The Expansion Election*. Peter Lang, New York.
- Swanson, David L. and Paolo Mancini (1996). *Politics, Media, and Modern Democracy. An International Study of Innovations in Electoral Campaigning and Their Consequences*. Praeger, Westport.
- Söderström, Herbert and Pelle Ahrnstedt (1956). Svenska dagstidningsjournalisters utbildning, rekrytering, attityder mm. Statsvetenskapliga institutionen, Uppsala universitet.
- Swanson, David L. and Paolo Mancini (1996). *Politics, Media, and Modern Democracy. An International Study of Innovations in Electoral Campaigning and Their Consequences*. Praeger, Westport 1996.
- Turow, Joseph (1997). *Breaking Up America. Advertisers and the New Media World*. University of Chicago Press, Chicago.
- Vallinder, Torbjörn (1962). *Ikampför demokratin. Rösträttsrörelsen i Sverige 1866–1900*. Natur & Kultur, Stockholm.
- Våge, Lars (2005). »Bloggvärlden från början«, in Våge, Stattin and Nygren (2005).
- Våge, Lars, Erik Stattin and Gunnar Nygren (2005). *Bloggtider*. Institutet för mediestudier, Sellin & Partner, Stockholm.
- Waldahl, Ragnar and Hanne Marthe Narud (2004). »Den 'korre' valgkampen: mediestoffet i fire uker før valget«, in Aardal, Krogstad and Narud (2004).
- Weibull, Lennart (2004). »Konkurrerande traditioner: A-pressen och den svenska journalistikens professionalisering«, *Arbetshistoria*, 3/2004.
- Weibull, Lennart (2005). *Allmänhetens bedömning av aktualitetsjournalistiken i svensk TV 2004*. Granskningsnämndens rapportserie nr 18. Granskningsnämnden för radio och tv.
- Weibull, Lennart (2006). *Vad, varför och vem? Anmälningar till Granskningsnämnden 2002–2004*. Granskningsnämndens rapportserie nr 19. Granskningsnämnden för radio och tv.
- Westerståhl, Jörgen (1964). *Dagspressen och den politiska opinionsbildningen*. Statsvetenskapliga institutionen, Göteborgs universitet.
- Westerståhl, Jörgen and Carl-Gunnar Janson (1958) *Politisk press*. Akademiförlaget, Göteborg.

- Westerståhl, Jörgen and Bo Särilvik (1956). *Svensk valrörelse 1954*. Icke-röstning, mediastudier. Arbetsrapport 11. Statsvetenskapliga institutionen, Göteborgs universitet.
- Wiese, Danielle R. and Bruce E. Gronbeck (2005). »Campaign 2004: developments in cyberpolitics«, in Denton (2005).
- Williams, Andrew Paul (2005). »The main frame: assessing the role of the internet in the 2004 U.S. presidential contest«, in Denton (2005).
- Zaller, John (2001). »The rule of product substitution in presidential campaign news«, in Elihu Katz and Yael Warshel, eds. *Election Studies. What's Their Use?* Westview Press, Boulder, Colorado.
- Åsard, Erik and W. Lance Bennett (1997). *Democracy and the Marketplace of Ideas*. Cambridge University Press, Cambridge.

Few Swedes get personally involved in Swedish election campaigns. Most contacts between parties and voters are indirect. Mass media play a vital role, but there are indications that media influence may be ebbing.

The power and influence of mass media and journalists may already have culminated. New channels and media may provide a power base for other groups. Swedish election campaigns face major changes as regards the power relations between media, parties and the citizens.

Media and elections in Sweden is the subject of the 2006 report from the SNS Democratic Audit. Members of the Audit team are Monika Djerf-Pierre (Göteborg University), Sören Holmberg (Göteborg University), Jesper Strömbäck (Mid Sweden University at Sundsvall), Lennart Weibull (Göteborg University) and Olof Petersson (SNS, Center for Business and Policy Studies).

The Swedish edition of the book (Mediernas valmakt) was published in June 2006 by SNS Förlag, Stockholm.

